

CONTRACT DOCUMENTS  
FOR

# **Pineview Galvanized Water Main Replacements**



CITY OF GOOSE CREEK  
DEPARTMENT OF PUBLIC WORKS

## INDEX

<u>CONTRACT INSTRUMENTS:</u>	<u>SECTION</u>	<u>PAGE</u>	<u>PAGE</u>
	<u>#</u>	<u>#</u>	<u>#</u>
ADVERTISEMENT FOR BIDS	01105	3	4
INFORMATION TO BIDDERS	01110	5	15
STATEMENT OF BIDDERS QUALIFICATIONS	01120	16	16
STATEMENT OF EQUIPMENT	01130	17	18
BID	01140	19	23
BID BOND	01160	24	24
AGREEMENT	01210	25	27
CERTIFICATE OF ACKNOWLEDGMENT OF CONTRACTOR, FOR AGREEMENT		28	28
PERFORMANCE BOND	01212	29	30
PAYMENT BOND	01214	31	32
CERTIFICATE OF ACKNOWLEDGMENT OF CONTRACTOR, FOR BONDS		33	33
CONTRACTORS CERTIFICATION FOR NPDES PERMIT	01215	34	34
CERTIFICATION		35	35
NOTICE OF INTENT TO AWARD		36	36
NOTICE OF AWARD		37	37
NOTICE TO PROCEED		38	38
CHANGE ORDER	01220	39	39
REQUEST FOR PAYMENT	01222	40	40
<b>GENERAL CONDITIONS</b>	01230		
1.0 GENERAL		41	48
2.0 OWNERS RIGHTS AND RESPONSIBILITIES		49	53
3.0 CONTRACTORS RIGHTS AND RESPONSIBILITIES		54	71
4.0 MATERIALS, EQUIPMENT, & WORKMANSHIP		72	79
5.0 INSURANCE, LEGAL RESPONSIBILITY, & SAFETY		80	85
6.0 PROGRESS & COMPLETION OF WORK		86	90
7.0 PAYMENTS TO THE CONTRACTOR		91	97
<b>SUPPLEMENTAL CONDITIONS</b>	01232	98	99

**SECTION 01105**

**ADVERTISEMENT FOR BIDS**

---

**PROJECT:** Pineview Galvanized Water Main Replacements

**OWNER:** City of Goose Creek, Department of Public Works

**RECEIPT OF BIDS:** Separate sealed bids for the above referenced project will be received by the Owner at their office, **200 Button Hall Ave., Goose Creek, SC 29445, until 2:00 p.m., local time at place of bidding, December 13th**, and at said office will be publicly opened and read aloud.

**PROJECT DESCRIPTION:** The Pineview Galvanized Water Main Replacement project will consist of the installation of +/- 5040 LF of new six-inch C900 PVC and Class 50 Ductile Iron Pipe to replace small, galvanized water mains that have reached their useful life. Included in the project is the installation of several new gate valves to increase our ability to isolate the main and installation of six new fire hydrant assemblies to increase fire protection. All tasks will be accomplished by a SC licensed utility contractor and inspected by city personnel

**DOCUMENTS:** Copies of the Documents may be obtained by visiting the City of Goose Creek's website ([www.cityofgoosecreek.com](http://www.cityofgoosecreek.com)). The contract documents may be examined online under the Government Tab, then Vendor Solicitations. Contract documents may be obtained or examined on or after September 28<sup>th</sup>, 2022.

**BIDDERS REQUIREMENTS:** SC Bidder's and Contractor's License and 5% BID BOND required. Pre-Bid conference to be held at the Department of Public Works Conference Room on **Wednesday, December 7, 2:00PM.**, is available for all bidders.

**SECURITY:** Each bid must be accompanied by a certified check of the Bidder, or by a Bid Bond made payable to the Owner, for an amount equal to not less than 5 percent of the total bid as a guarantee that, if the bid is accepted, the required Agreement will be executed and that a 100% Performance Bond and 100% Payment Bond will be furnished.

**OWNER'S RIGHTS:** The Owner reserves the right to waive any informalities in bidding and to reject all Bids if it is in the Owner's best interest to do so. Unless all bids are rejected, award will be to the low responsive, responsible Bidder.

BIDDER'S RIGHTS: Under South Carolina State Law, Section 11-35-4210(1), any actual bidder, offeror, contractor, or subcontractor who is aggrieved in connection with the intended award or award of a contract shall protest to the Director of Public Works within fifteen days of the date the Notice of Intent to Award is posted. The date, time, and location of posting of the Notice of Intent to Award will be announced at bid opening. In addition to the posted notice, Notice of Intent to Award will be given to all bidders responding to the solicitation. Sixteen days after Notice of Intent to Award is given, the agency may enter a contract with the bidder named in the notice in accordance with the provisions of Section 11-35-1520(10).

---

Chuck Denson, Director  
City of Goose Creek Department of Public Works

(End of Section 01105)

## SECTION 01110

### INFORMATION FOR BIDDERS

---

LAWS AND REGULATIONS: All applicable laws, ordinances, and the rules and regulations of all authorities having jurisdiction over construction of the project shall apply to the Contract throughout, and they will be deemed to be included as though herein written out in full.

LICENSES: The provisions of Title 40 Chapter 11 of the South Carolina Code of Laws, and Chapter 29 of the South Carolina Code of Regulations, which govern the licensure of General Contractors, shall be deemed a part of these documents as if written herein.

All Bidders submitting a Bid shall have a currently valid South Carolina General Contractor's License. The license number shall be shown on the bid form immediately below the signature and on the face of the sealed envelope containing the submitted Bid. Subcontractors who will be engaged by the General Contractor shall also hold the required licenses.

The successful Bidder and all subcontractors will be required to obtain a business license from the City of Goose Creek prior to beginning work if said Bidder does not have a current license.

NON-RESIDENT CONTRACTORS: A Bidder, who is a non-resident contractor, shall be aware of Section 12-9-310, Article 3, of the South Carolina Income Tax Act of 1926, as amended. This article requires the Owner entering into a contract with a non-resident taxpayer, where such contract exceeds ten thousand dollars (\$10,000), to withhold two percent (2%) of each and every payment made to the non-resident.

The funds deducted from the payment made to the non-resident taxpayer are funds deemed to be held in trust for the State of South Carolina and will be reported by the Owner to the South Carolina Tax Commission. This Deduction is in addition to the retainage deductions specified in the General Conditions. Modifications to the South Carolina Income Tax Act made January 1, 1993, allow a non-resident contractor to apply for an exemption or partial exemption from the two percent (2%) withholding rule. The non-resident contractor must complete a "Nonresident Taxpayer Request for Exemption Affidavit" (Form WH 303), "Nonresident Taxpayer Affidavit" (Form WH 302) and a subcontractors list. The South Carolina Tax Commission will make the determination and notify both contracting parties of the qualified exempt or partially exempt contracts.

All contracts for \$10,000 or more with non-residents which do not qualify for exemption will require the withholding of two percent (2%) from each payment as described above. The non-resident contractor may elect to post a surety bond with the South Carolina Tax Commission to eliminate this withholding requirement. The non-resident must complete and

submit the Bond (Form L-2074) and a "Nonresident Taxpayer Affidavit" (Form WH 302) to the South Carolina Tax Commission for review and approval. The Owner must receive verification from the South Carolina Tax Commission if this deduction is to be waived.

The above referenced forms may be obtained from the South Carolina Tax Commission located at 301 Gervais Street, Columbia, South Carolina (mailing address - P.O. Box 125, Columbia, South Carolina 29214).

EXAMINATION OF SITE: Each Bidder shall visit the site of proposed work and fully acquaint himself with conditions relating to construction and labor so he may fully understand facilities, difficulties, and restrictions attending execution of work under contract. By executing the Agreement, the Contractor represents that he has visited the site, familiarized himself with the local conditions under which the work is to be performed, and correlated his observations with the requirements of the Contract Documents.

The Bidder will notify the Owner of the date and time Bidder proposes to examine the Project Location. The Bidder shall confine examination to the specific areas designated for the proposed construction, including easements and public right-of-ways. If, due to some unforeseen reason, the Owner's proceedings for obtaining the proposed construction site (including easements) have not been completed, the Bidder may enter the site only with the express consent of the property owner. The Bidder is solely responsible for any damages caused by examination of the site.

WORK IN STATE AND COUNTY RIGHTS-OF-WAY: The Owner will obtain the necessary easements and permits for construction across both County and State Highway rights-of-way. The Contractor shall abide by all rules, regulations, and requirements of these agencies in regard to construction under this contract, including the giving of notices, provisions for inspections, and employment of such methods of construction as may be required. Wherever these Specifications may be in conflict with the regulations or requirements of these agencies, such regulations shall govern, and these Specifications shall be modified to such extent as necessary to conform with the said rules, regulations, and requirements. Wherever additional costs are incurred due to requirements of these agencies, such additional periods of maintenance, special features of construction, etc., all such costs shall be included in the prices bid. No additional compensation will be allowed for such costs after award of the Contract.

EASEMENTS: The Owner has obtained, or will obtain, permanent easements and temporary construction easements through private property. The temporary construction easements entitle the Contractor to the occupancy and use of the designated area near or adjacent to the work for purposes related to the work. The Contractor will not encroach on any property unless it has been established that easements have been obtained. On all other land, the Contractor has no rights unless he obtains permission from the proper parties.

EXAMINATION OF DRAWINGS AND SPECIFICATIONS: Each Bidder shall carefully examine the Drawings, Specifications, all Addenda and revisions thereto, and thoroughly familiarize himself with the detailed requirements thereof prior to submitting a Bid. If any Bidder is in doubt of the meaning of any part of the Drawings, Specifications or other Documents or if any error, discrepancy, conflict or omission is noted, the Bidder shall immediately contact the Engineer in writing and request clarification. The Engineer will clarify the intent of the Documents and/or correct such error, discrepancy, conflict or omission and will notify all Bidders by Addendum when the extent or cost of work will be appreciably affected. No allowance will be made after Bids are received for a Bidders oversight.

CONFLICT OR INCONSISTENCIES: Bidders are also cautioned that if more than one set of conditions are included in the contract, then in case of a conflict between any of the conditions the strictest will apply. See section 1.3.

ITEMS AND INDETERMINATE ITEMS: The work to be done under this Contract has been divided into items, and items having sub-items, to enable each Bidder to bid on the different portions of the work in accordance with his unit price estimate of their cost, and so that the actual quantity of work executed under each item, or sub-item, may be paid for at the unit price bid for the particular item, or sub-item, even though such quantity is greater or less than the estimated quantity stated in the Bid.

ESTIMATED QUANTITIES: Bidders must satisfy themselves of the accuracy of the estimated quantities in the Bid Schedule by examining the site and reviewing the Specifications, Drawings, and Addenda. After Bids have been submitted, the Bidder shall not assert that there was a misunderstanding concerning the quantities or the nature of the work to be done.

RIGHT TO INCREASE OR DECREASE THE AMOUNT OF WORK: The work comprises approximately the quantities shown in the bid form that will be used as a basis for comparison of Bids and not for final estimate. The Owner does not, by expression or by implication, agree that the actual amount of work shall correspond with the estimated quantities.

The Owner reserves the right to alter the quantities of work to be performed, or to extend or shorten the improvements, at any time when necessary, and the Contractor shall perform the work as altered, increased or decreased. Payment for such increased or decreased quantity will be in accordance with General Conditions subsection 7.12 entitled Payment for Extra Work. No allowance will be made for any change in anticipated profits, nor shall such changes be considered as waiving or invalidating any conditions or provisions of the Contract and Bond.

INFORMATION NOT GUARANTEED: All information given on the Drawings or in the Contract Documents relating to subsurface conditions, existing structures, location of utilities, sewer inverts, or other information on existing facilities is from the best sources at present available to the Owner. All such information is furnished only for the information and convenience of the Bidders.

It is agreed and understood that the Owner does not warrant or guarantee that the conditions, pipes, or other structures encountered during construction will be the same as those indicated on the Drawings or in the Contract Documents. The Bidder must satisfy himself regarding the character, quantities, and conditions of the various materials and the work to be done.

It further is agreed and understood that the Bidder or the Contractor will not use any of the information made available to him or obtained in any examination made by him in any manner as a basis or ground of claim or demand of any nature against the Owner or the Engineer, arising from or by reason of any variance which may exist between the information offered and the actual materials or structures encountered during the construction work, except as may otherwise be provided for in the Contract Documents.

If any work is performed by the Contractor or any subcontractor, prior to adequate verification of applicable data, any resultant extra cost for adjustment of work necessary to conform to existing conditions, or damage to existing facilities, shall be assumed by the Contractor without reimbursement or compensation by the Owner.

COMPLETE WORK REQUIRED: It is the intent of the Drawings and Specifications to provide a complete and usable facility. The Contractor's work shall be based on the Drawings and Specifications, but shall include all materials, labor, and appurtenances necessary to produce a complete and workable facility whether or not such material and appurtenances are shown on the Drawings or described in the Specifications.

The Drawings, Specifications, and all supplementary documents are essential parts of the Contract, and requirements occurring in one are as binding as though occurring in all. They are intended to be cooperative, to describe and provide for a complete work. In case of discrepancy on the Drawings, figured dimensions shall govern. In case of omissions from the Specifications as to equipment, materials or quantities therefore, the Drawings shall govern.

**The Bidder shall call to the attention of the Engineer obvious omissions of such magnitude as to affect the strength, adequacy, function, completeness, or cost of any part of the work in ample time for amendment by Addendum prior to bid opening date.**

ADDENDA AND INTERPRETATIONS: Prior to the contract award, the Engineer will not make any oral interpretation of the Drawings, Specifications, or Bid Documents to any Bidder.



Every request for such interpretation shall be **in writing** addressed to CITY OF GOOSE CREEK, DEPARTMENT OF PUBLIC WORKS, P.O. BOX 1768, GOOSE CREEK, S.C. 29445; ATTENTION: DIRECTOR. To be considered, such request must be received at least seven (7) days prior to the Bid Opening Date. All such interpretations and any supplemental instructions will be issued in written Addenda to the Specifications which will be faxed and mailed by certified mail with return receipt requested to all prospective Bidders (at the addresses furnished for such purposes), not later than five (5) days prior to the Bid Opening Date. Failure of any Bidder to receive such Addendum or interpretation shall not relieve such Bidder from any obligation under his Bid as submitted. All Addenda so issued shall become part of the Contract Documents and noted on the Bid Form.

**PRE-BID CONFERENCE:** The Pre-Bid conference is available for all bidders. It will be held in the conference room at the Department of Public Works, 200 Button Hall Ave, at 2:00 pm on Wednesday, December 7, 2022. The Prebid Conference is for discussion of items of special interest to the Owner that may affect the Bids. An addenda based on the items discussed will be emailed upon request.

**SUBMITTING BIDS:** Each Bid must be submitted on the prescribed bid form. All blank spaces for bid prices must be filled in, in ink or typewritten, and the Bid must be fully completed and executed when submitted. Only one copy of the bid form is required.

Bidders are cautioned that it is the responsibility of each individual Bidder to assure that his Bid is in the possession of the responsible official or his designated alternate prior to the stated time and at the stated place of the bid opening. Owner is not responsible for Bids delayed by mail or delivery services of any nature.

**FORM OF BID:** All Bids must be submitted on the blank bid form provided therefore and must state the total price for which the Bidder will complete the work in accordance with the terms of the Contract Documents. All blank spaces must be filled in and there shall be no interpretations, alterations, or erasures.

The Bid must be signed manually by a principal, or an officer duly authorized to make contracts. The Bidder's legal name must be fully stated, and the name and title of the person signing must be typed below his signature.

**BID SUBMISSION REQUIREMENTS:** Each Bid must be submitted in an opaque sealed envelope, plainly marked on the outside, addressed and delivered as shown below. If forwarded by mail, the sealed envelope containing the Bid must be enclosed in another envelope addressed to the Owner at the following addresses. Address to the Attention of: Chuck Denson, Director.

Hand Carry  
To: City of Goose Creek  
Department of Public Works  
200 Button Hall Ave.  
Goose Creek, SC 29445

Mailing Address  
To: City of Goose Creek  
Department of Public Works  
Post Office Box 1768  
Goose Creek, SC 29445

The Bid shall also have on the envelope thereof the following information:

1. Upper Left-Hand Corner: Bidder's Name  
Bidder's Address
2. Lower Left-Hand Corner: Bid for Construction of:  
Pineview Galvanized Water Main Replacements
3. In the middle of the envelope:

South Carolina General Contractor's License No. \_\_\_\_\_

Classification \_\_\_\_\_

Expiration Date \_\_\_\_\_

**BID SECURITY:** Each Bid must be accompanied by a certified check of the Bidder, or a Bid Bond duly executed by the Bidder as principal and having as surety thereon a surety company qualified to do business under the laws of the State of South Carolina and satisfactory to the Owner, in an amount not less than five percent (5%) of the Bid.

Such check or Bid Bond will be returned to all except the three (3) lowest Bidders within three (3) days after the opening of Bids, and the remaining checks or Bid Bonds will be returned promptly after the Owner and the accepted Bidder have executed the Agreement. If no award has been made within ninety (90) calendar days after the date of the opening of Bids, such check or Bid Bond will be returned upon demand of the Bidder at any time thereafter, so long as he has not been notified of the acceptance of his Bid.

**TELEGRAPHIC MODIFICATIONS:** Any Bidder may modify his Bid by telegraphic communication at any time prior to the scheduled closing time for receipt of Bids, provided such telegraphic communication is received by the Owner prior to the closing time; and, provided further, the Owner is satisfied that a written confirmation of the telegraphic modification over the signature of the Bidder was mailed prior to the closing time. Telegraphic communication should not reveal the Bid price but should provide the addition or subtraction or other modification so that the final prices or terms will not be known by the Owner until the sealed Bid is opened. If written confirmation is not received within two (2) calendar days from the closing time, no consideration will be given to the telegraphic modification.

WITHDRAWAL OF BIDS: Any Bidder may withdraw his Bid, either personally or by written request, at any time prior to the scheduled opening of Bids or authorized postponement thereof. Otherwise, Bidder may not withdraw his Bid for a period of ninety (90) calendar days after the date set for the opening thereof, and all Bids shall be subject to acceptance by the Owner during this period.

RECEIPT AND OPENING OF BIDS: Bids will be received at the time and place as specified in the Advertisement for Bids, and then at said office publicly opened and read aloud.

The date, time, and location of posting of the Notice of Intent to Award will be announced at bid opening. In addition to the posted notice, Bid Tabulations and Notice of Intent to Award will be mailed to all bidders responding to the solicitation.

COMPARISON OF BIDS: Bids will be compared on the basis of the prices stated in the Bid. If there is a discrepancy between the unit price and or the computed total amount, the unit price shall govern.

IRREGULAR BIDS: A Bid will be considered irregular and may be rejected for any one of the following reasons:

1. If the Bid is on a form other than that furnished by the Owner; or if the form is altered or any part detached.
2. If there are unauthorized additions, conditional or alternate bids, or irregularities of any kind which tend to make the Bid incomplete, indefinite, or ambiguous in its meaning.
3. If the Bidder adds any provisions reserving the right to accept or reject an award, or to enter into a contract pursuant to an award.
4. If the Bid does not contain a price for each item listed.
5. If the Bid does not contain the aggregate of the Bid, obtained by adding the extended amounts of the various items, if applicable.
6. If the Bid contains obviously unbalanced bid prices.
7. If there is reason to believe that any Bidder is interested in more than one Bid on the same project or that there has been collusion among the Bidders.

ACCEPTANCE OR REJECTION OF BIDS: The Owner reserves the right to reject any and all Bids when such rejection is in the interest of the Owner; to reject the Bid of a Bidder who has previously failed to perform properly or complete contracts of a similar nature on time; and to reject the Bid of a Bidder who is not, in the Owner's opinion, in a position to perform the Contract. The Owner reserves the right to waive any informalities and technicalities in bidding. The Owner may also accept or reject any of the alternates that may be set forth on the Bid.

ABILITY AND EXPERIENCE OF BIDDER: It is the purpose of the Owner not to award this Contract to any Bidder who does not furnish satisfactory evidence that he has the experience of successfully completing projects of this type and magnitude and that he has sufficient capital, equipment, plant, and personnel to enable him to prosecute the work successfully and to complete it in the time named.

The Owner may make such investigation as it deems necessary to determine the ability of the Bidder to perform the work, and the Bidder shall furnish to the Owner, under oath if so required, all such information and data for this purpose as the Owner may request.

RESPONSIVE BIDDERS: A responsive Bidder shall be one who submits a Bid in the proper form without qualifications or intent other than as called for in the Contract Documents and who binds himself or herself on behalf of the Bid to the Owner with the proper Bid Bond completed and attached, and who properly completes all forms required to be completed and submitted at the time of the Bidding. The Bidder shall furnish all data required by these Contract Documents. Failure to do so may result in the Bid being declared non-responsive.

RESPONSIBLE BIDDERS: A responsible Bidder shall be one who can fulfill the following requirements:

- a. The Bidder shall maintain a permanent place of business. This requirement applies to the Bidder where the Bidder is a division of a corporation, or where the Bidder is 50 percent or more owned by a person, corporation or firm.
- b. The Bidder shall demonstrate adequate construction experience and sufficient equipment resources to properly perform the work under and in conformance with the Contract Documents. This evaluation will be based upon a list of completed or active projects and a list of construction equipment available to the Bidder to perform the work. The Owner may make such investigations as deemed necessary to determine the ability of the Bidder to perform the work, and the Bidder shall furnish to the Owner all such information and data for this purpose as the Owner may reasonably request. The Owner reserves the right to reject any Bid if the evidence submitted by, or investigation of, such Bidder fails to satisfy the Owner that such Bidder is properly qualified to carry out the obligations of the Contract and to complete the Project contemplated therein.
- c. The Bidder shall demonstrate financial resources of sufficient strength to meet the obligations incident to the performance of the work covered by these Contract Documents. The ability to obtain the required Performance and Payment Bonds will not alone demonstrate adequate financial capability.

Acceptance of Bidder's documentation and substantiation, or Contract Award by the Owner does not relieve Bidder of liability for non-performance covered in the Contract Documents, nor exempt the Bidder from any other legal recourse the Owner may elect to pursue.

**BIDS AND QUALIFICATIONS:** Before a Bid is considered for award, the Bidder may be requested by the Owner to submit a statement of facts in detail as to his previous experience in performing similar or comparable work, and of his business and technical organization and financial resources and plant available to be used in performing the contemplated work.

**DISQUALIFICATION OF BIDDERS:** More than one Bid from an individual, a firm or partnership, a corporation or any association, under the same or different names, will not be considered. Reasonable grounds for believing that any Bidder is interested as a principal in more than one Bid for the work contemplated will cause the rejection of all Bids in which such Bidder is believed to be interested. Any or all Bids will be rejected if there is reason to believe that collusion exists among the Bidders. Contracts will be awarded only to responsible Bidders capable of performing the class of work contemplated within the time specified and having sufficient resources and finances to carry on the work properly.

**METHOD OF AWARD:** The Contract will be awarded to the responsive, responsible Bidder submitting the lowest Bid complying with the conditions of the Contract Documents. Award will be made on the basis of the prices given in the Base Bid or a combination of the Base Bid and Alternates, at the Owner's option. The Owner reserves the right to reject any and all Bids and to waive any minor irregularities in Bids received whenever such rejection or waiver is in the Owner's interest.

**NOTICE OF INTENT TO AWARD:** shall be mailed to all bidders, with the Bid Tabulations, by the date specified at Bid opening. From the time of posting of the Notice of Intent to Award, bidders have fifteen (15) days to protest in conformance with South Carolina State Law, Section 11-35-4210(1).

**NOTICE OF AWARD:** after the 15-day protest period defined in South Carolina State Law, Section 11-35-4210(1) has expired, the Owner shall issue a Notice of Award.

**GUARANTY BONDS:** The Bidder to whom the contract is awarded will be required to execute the Agreement and obtain the Performance Bond and Payment Bond, each in the sum of the full amount of the Contract Price, within ten (10) calendar days from the date when Notice of Award is delivered to the Bidder.

The Bidder as principal, and a corporate surety company qualified to do business under South Carolina State Law and satisfactory to the Owner, shall duly execute and acknowledge the Bonds for the faithful performance of the Contract and payment for labor and materials. The Contractor shall pay the premiums for such Bonds.

Each Bond must be irrevocable, and valid for one year beyond the date of final acceptance of the project, or for two years for any building in the project.

POWER OF ATTORNEY FOR BONDS: Attorneys-in-fact who sign Bid or Performance or Payment Bonds must file with each Bond a certified and dated copy of their power of attorney.

EXECUTION OF CONTRACT: The Owner, within ten (10) calendar days of receipt of acceptable Performance Bond, Payment Bond, and Agreement signed by the party to whom the Agreement was awarded, shall sign the Agreement and return to such party an executed duplicate of the Agreement. Should the Owner not execute the Agreement within such period, the Bidder may by written notice withdraw his signed Agreement. Such notice of withdrawal shall be effective upon receipt of the notice by the Owner.

LIQUIDATED DAMAGES FOR FAILURE TO ENTER INTO CONTRACT: The successful Bidder, upon his failure or refusal to execute and deliver the Contract and Bonds required within ten (10) calendar days after he has received notice of the acceptance of his Bid, shall forfeit to the Owner as liquidated damages for such failure or refusal the security deposited with his bid.

PRE-CONSTRUCTION CONFERENCE: After the Contractor signs the AGREEMENT, and submits all required documents therefore, and prior to issuance of the NOTICE TO PROCEED, a pre-construction conference will be held with representatives of the Owner, Contractor, and the Engineer. At this conference, the construction schedule and inspection schedule will be approved. Any problems with the Plans & Specifications will be resolved, and the Project Staff of the Owner and the Contractor will receive approval.

SCHEDULE OF COMPLETION: At the Pre-Construction Conference, the Contractor shall deliver to the Owner a Schedule of Completion on forms approved by the Owner.

The schedule shall be set up in a Critical Path format, or other method approved by the Owner, and shall be supported by documentation including material and equipment delivery schedules, number and classification of employees to be employed on the Work, list of processes which can be completed simultaneously, or which cannot start until another part is completed, etc.

The schedule shall show the commencement and completion dates of the various subdivisions of work required by the Contract Documents, and all activities required to accomplish the Work. No activity included in the schedule shall have duration greater than five (5) days.

NOTICE TO PROCEED: The Notice to Proceed will be issued within ten (10) calendar days of the execution of the Agreement by the Owner. Should there be reasons why the Notice to

Proceed cannot be issued within such period, the time may be extended by mutual agreement between the Owner and Contractor. If the Notice to Proceed has not been issued within the ten (10) calendar day period or within the period mutually agreed upon, the Contractor may terminate the Agreement without further liability on the part of either party.

TIME FOR COMPLETION: The Bidder must agree to commence work within 10 days of the Notice To Proceed stipulated in the Agreement. The Bidder also must agree to fully complete the project within 180 days.

LIQUIDATED DAMAGES: The Bidder must agree to pay as liquidated damages the amount set forth in the Agreement for each consecutive calendar day that the work is incomplete after the date of completion.

## SECTION 01120

### STATEMENT OF BIDDER'S QUALIFICATIONS

---

All questions must be answered, and the data given must be clear and comprehensive. This statement must be notarized. If necessary, questions may be answered on separate attached sheets. The Bidder may submit any additional information desired. Attach all additional sheets to these Contract Documents.

1. Name of Bidder:
2. Permanent main office address:
3. When organized:
4. If a Corporation, where incorporated:
5. How many years have you been engaged in the contracting business under your present firm or trade name?
6. Contracts on hand: (Schedule these, showing amount of each contract and the appropriate anticipated dates of completion):
7. General character of work performed by your company:
8. Have you ever failed to complete any work awarded to you? If so, where and why?
9. Have you ever defaulted on a contract? If so, where and why?
10. List the most important projects recently completed by your company, stating the approximate cost for each, and the month and year completed:
11. Experience in construction work similar in importance to this project:
12. Background and experience of the principal members of your organization, including officers:
13. The undersigned hereby authorizes and requests any person, firm, or corporation to furnish any information requested by the local public agency in verification of the recitals comprising this Statement of Bidder's Qualifications.



**SECTION 01130**

**STATEMENT OF EQUIPMENT**

---

Show machinery and other equipment available to Contractor for prosecuting the work included in Contract. (To be filled in by Contractor and submitted with bid.)

---

Available Machinery and Other Equipment Kind-Size-Capacity	Location	Ownership	Date Proposed To Be Placed On Work
--	----------	-----------	--

---

The above is a true statement of the equipment available to the undersigned Bidder for prosecuting the Work included in the Contract. Where it is shown that the equipment is not owned by the Bidder, arrangements have been made with the owners to furnish the equipment.

Signed: \_\_\_\_\_

Title: \_\_\_\_\_

Dated this \_\_\_\_\_ day of \_\_\_\_\_, 20\_\_

\_\_\_\_\_  
(Name of Bidder)

By: \_\_\_\_\_

Title: \_\_\_\_\_

STATE OF SOUTH CAROLINA )  
 )  
COUNTY OF BERKE LEY )

\_\_\_\_\_ being duly sworn deposes and says that he is  
\_\_\_\_\_ of \_\_\_\_\_ and that the answers to the  
foregoing questions and all statements therein contained are true and correct. Subscribed and  
sworn to before me this \_\_\_\_\_ day of \_\_\_\_\_, 20 \_\_\_\_\_.

\_\_\_\_\_  
(Notary Public)

My Commission Expires: \_\_\_\_\_ (SEAL)  
(Date)

(End of Section 01130)

**SECTION 01140**

**BID**

---

TO: City of Goose Creek  
Department of Public Works  
200 Button Hall Ave.  
Goose Creek, SC 29445

FROM: \_\_\_\_\_  
\_\_\_\_\_  
\_\_\_\_\_

of the City of \_\_\_\_\_, County of \_\_\_\_\_, and  
State of \_\_\_\_\_, hereinafter called "Bidder".

PROJECT: Pineview Galvanized Water Main Replacements

Gentlemen:

The Bidder, in compliance with your Advertisement for Bids for the construction of above referenced project, having examined the Drawings and Specifications with related documents and the site of the proposed work, and being familiar with all of the conditions surrounding the construction of the proposed project, including the availability of materials and labor, hereby proposes to furnish all labor, materials, and supplies, and to construct the project in accordance with the Contract Documents, within the time set forth therein, and the prices stated below. These prices are to cover all expenses incurred in performing the work required under the Contract Documents, of which this proposal is a part.

The Bidder declares that he has carefully examined the site of the proposed Work and fully informed and satisfied himself as to the conditions there existing, the character and requirements of the proposed Work, and the difficulties attendant upon its execution, and that he has carefully read and examined the Drawings, the annexed proposed Agreement, and the Specifications and other Contract Documents therein referred to and knows and understands the terms and provisions thereof.

Bidder understands that information relative to existing structures, apparent and latent conditions, and natural phenomena, as furnished to him on the Drawings, in the Contract Documents, or by the Owner or the Engineer, carries no guarantee expressed or implied as to its completeness or accuracy, and he has made due allowance, therefore.

TIME FOR COMPLETION AND LIQUIDATED DAMAGES: Bidder hereby agrees to commence work under this contract within 10 days of receipt of the Notice to Proceed and to fully complete the project within 180 consecutive calendar days thereafter.

Bidder also agrees to pay \$ 500 /day as liquidated damages for each consecutive calendar day thereafter as hereinafter provided in the General Conditions.

ADDENDA: Bidder acknowledges receipt of the following Addenda:

Addendum No. \_\_\_\_\_ Date \_\_\_\_\_  
Addendum No. \_\_\_\_\_ Date \_\_\_\_\_  
Addendum No. \_\_\_\_\_ Date \_\_\_\_\_  
Addendum No. \_\_\_\_\_ Date \_\_\_\_\_

## BID SCHEDULE

### Dogwood Avenue Water Main Replacement

ITEM	DESCRIPTION	UNITS	QTY	UNIT	COST
				PRICE	
1	8" C-900 Class 150 PVC pipe	LF	20		
2	8" Coupling	EA	0		
3	8" Resilient Wedge Gate Valve	EA	2		
4	8"x6"x8" M.J. Tee	EA	1		
5	6" C-900 Class 150 PVC pipe	LF	1590		
6	6" Class 50 DI pipe	LF	80		
7	6"x6"x6" M.J. Tee	EA	1		
8	6" Resilient Wedge Gate Valve	EA	5		
9	6" Grip Rings or Mega Lugs	EA	8		
10	Fire Hydrant, Mueller A421 or A-D Mk 73	EA	1		
11	Valve Boxes, 3-4'	EA	7		
12	Installation of near side service lines	EA	8		
13	Installation of far side service lines	EA	9		
14	12 GA Tracer Wire	ROLL	3		

**Base Bid Calculated Total:** \_\_\_\_\_

### ALTERNATE 1

### Laurel Avenue Water Main Replacement

ITEM	DESCRIPTION	UNITS	QTY	UNIT	COST
				PRICE	
1	8" C-900 Class 150 PVC pipe	LF	20		
2	8" Coupling	EA	2		
3	8"x6"x8" M.J. Tee	EA	1		
4	6" C-900 Class 150 PVC pipe	LF	1270		
5	6" Resilient Wedge Gate Valve	EA	1		
6	6" Grip Rings or Mega Lugs	EA	6		
7	Fire Hydrant, Mueller A421 or A-D Mk 73	EA	1		
8	Valve Boxes, 3-4'	EA	2		
9	Installation of near side service lines	EA	6		
10	Installation of far side service lines	EA	8		
11	12 GA Tracer Wire	ROLL	3		

**Alternate 1 Calculated Total:** \_\_\_\_\_

**ALTERNATE 2**

**Birch Avenue Water Main Replacement**

ITEM	DESCRIPTION	UNITS	QTY	UNIT	COST
				PRICE	
1	8" C-900 Class 150 PVC pipe	LF	20		
2	8" Coupling	EA	2		
3	8" Resilient Wedge Gate Valve	EA	2		
4	8" Grip Rings or Mega Lugs	EA	4		
5	8"x6"x8" M.J. Tee	EA	1		
6	6" C-900 Class 150 PVC pipe	LF	1320		
7	6" Class 50 DI pipe	LF	40		
8	6"x6"x6" M.J. Tee	EA	6		
9	6" Resilient Wedge Gate Valve	EA	5		
10	6" Grip Rings or Mega Lugs	EA	30		
11	6" Foster Adaptor	EA	1		
12	Fire Hydrant, Mueller A421 or A-D Mk 73	EA	1		
13	Valve Boxes, 3-4'	EA	7		
14	Installation of near side service lines	EA	8		
15	Installation of far side service lines	EA	7		
16	12 GA Tracer Wire	ROLL	3		

Alternate 2 Calculated Total: \_\_\_\_\_

**ALTERNATE 3**

The \_\_\_\_\_

**Ellen Street Water Main Replacement**

ITEM	DESCRIPTION	UNITS	QTY	UNIT	COST
				PRICE	
1	8" Resilient Wedge Gate Valve	EA	3		
2	8" Grip Rings or Mega Lugs	EA	16		
3	8"x6"x8" M.J. Tee	EA	3		
4	6" C-900 Class 150 PVC pipe	LF	1980		
5	6" Class 50 DI pipe	LF	80		
6	6"x6"x6" M.J. Tee	EA	1		
7	6" Resilient Wedge Gate Valve	EA	7		
8	6" Grip Rings or Mega Lugs	EA	10		
9	6" Foster Adaptor	EA	3		
10	Fire Hydrant, Mueller A421 or A-D Mk 73	EA	3		
11	Valve Boxes, 3-4'	EA	9		

12	Installation of near side service lines	EA	11		
13	Installation of far side service lines	EA	9		
14	12 GA Tracer Wire	ROLL	4		

**Alternate 3 Calculated Total:** \_\_\_\_\_

**ALTERNATE 4**

**Francis Street Water Main Replacement**

ITEM	DESCRIPTION	UNITS	QTY	UNIT	COST
				PRICE	
1	8" Coupling	EA	2		
2	8" Resilient Wedge Gate Valve	EA	2		
3	6" C-900 Class 150 PVC pipe	LF	675		
4	6" Class 50 DI pipe	LF	40		
5	6"x6"x6" M.J. Tee	EA	1		
6	6" Resilient Wedge Gate Valve	EA	2		
7	6" Grip Rings or Mega Lugs	EA	8		
8	Fire Hydrant, Mueller A421 or A-D Mk 73	EA	1		
9	Installation of near side service lines	EA	3		
10	Installation of far side service lines	EA	3		
11	12 GA Tracer Wire	ROLL	1		
12	Detectable Tape – Water	ROLL	2		

**Alternate 4 Calculated Total:** \_\_\_\_\_

**BASE BID TOTAL** \_\_\_\_\_

**BID TOTAL (all alternates):** \_\_\_\_\_

Additions to work and deletions from work shall be paid in accordance with these unit prices.

The above unit prices shall include all labor, materials, dewatering, shoring, removal, overhead, profit, insurance, taxes, fees, etc., to cover the finished work of the several kinds called for.

Bidder understands that the Owner reserves the right to reject any or all bids and to waive any informality in the bidding.

The Bidder agrees that this Bid shall be good and may not be withdrawn for a period of 90 calendar days after the scheduled closed time for receiving bids.

Upon receipt of written notice of the acceptance of this Bid, Bidder will execute the formal Agreement attached within 10 days and deliver Surety bonds as required by the General Conditions. The bid security attached in the sum of \_\_\_\_\_ (\$\_\_\_\_\_) is to become the property of the Owner in the event the Agreement and Bond are not executed within the time above set forth as liquidated damages for the delay and additional expense to the Owner caused thereby.

The undersigned declares that his firm is \_\_\_\_\_  
Name of Firm  
A corporation organized and existing under the laws of the  
State of \_\_\_\_\_

The undersigned declares that the person or persons signing this proposal is fully authorized to sign the proposal on behalf of the firm listed and to fully bind the firm listed to all the conditions and provisions thereof.

It is agreed that no person or persons or company other than the firm listed below or as otherwise indicated hereinafter has any interest whatsoever in this proposal or the contract that may be entered into as a result thereof, and that in all respects the proposal is legal and fair, submitted in good faith, without collusion or fraud.

Respectfully Submitted:

\_\_\_\_\_  
Contractor

By:

\_\_\_\_\_

(Title)

\_\_\_\_\_

(Address)

(SEAL)

\_\_\_\_\_

(Corporations)

S.C. General Contractor's License No. \_\_\_\_\_

S.C. General Contractor's License Group \_\_\_\_\_

(End of Section 01140)



**SECTION 01160**

**BID BOND**

---

KNOW ALL MEN BY THESE PRESENTS, that we, the undersigned, \_\_\_\_\_ as Principal, and \_\_\_\_\_ as Surety, are hereby held and firmly bound unto the City of Goose Creek Department of Public Works as OWNER in the penal sum of 5% (five percent) of BID for the payment of which, well and truly to be made, we hereby jointly and severally bind ourselves, successors and assigns.

Signed, this \_\_\_\_\_ day of \_\_\_\_\_, 20\_\_.

The Condition of the above obligation is such that whereas the principal has submitted to the City of Goose Creek Department of Public Works a certain BID, attached hereto made a part hereof to enter into a contract in writing, for the construction of the Pineview Galvanized Water Main Replacements as described within Contract Documents dated \_\_\_\_\_, by the Owner.

NOW THEREFORE, (a) If said BID shall be rejected, or  
(b) If said BID shall be accepted and the Principal shall execute and deliver a contract in the Form of Contract attached hereto (properly completed in accordance with said BID) and shall furnish a BOND for his faithful performance of said contract, and for the payment of all persons performing labor or furnishing materials in connection therewith, and shall in all other respects perform the agreement created by the acceptance of said BID, then this obligation shall be void, otherwise the same shall remain in force and effect; it being expressly understood and agreed that the liability of the Surety for any and all claims hereunder shall, in no event, exceed the penal amount of this obligation as herein stated.

The Surety, for value received, hereby stipulates and agrees that the obligations of said Surety and its BOND shall be in no way impaired or affected by an extension of the time within which the OWNER may accept such BID; and said Surety does hereby waive notice of any such extension.

IN WITNESS WHEREOF, the Principal and Surety have hereunto set their hands and seals, and such of them as are corporations have caused their corporate seals to be hereto affixed and these presents to be signed by their proper officers, the day and year first set forth above.

\_\_\_\_\_  
(Principal) (L.S.)

\_\_\_\_\_  
Surety

By: \_\_\_\_\_

IMPORTANT - Surety companies executing BONDS must appear on the Treasury Department's most current list (Circular 570 as amended) and be authorized to transact business in the State of South Carolina.

**SECTION 01210**

**AGREEMENT**

THIS AGREEMENT made this \_\_\_\_\_ day of \_\_\_\_\_, 20\_\_\_\_, by  
and between \_\_\_\_\_ City of Goose Creek Department of Public Works \_\_\_\_\_.

acting herein through its \_\_\_\_\_ **DIRECTOR** \_\_\_\_\_  
(Title of Authorized Official)

hereinafter called "OWNER" and \_\_\_\_\_  
(Name of Contractor)

doing business as \_\_\_\_\_  
(an Individual),(a Partnership) or (a Corporation)

of the City of \_\_\_\_\_ County of \_\_\_\_\_ and  
State of \_\_\_\_\_ hereinafter called "Contractor."

WITNESSETH: That for and in consideration of the payments and agreements hereinafter mentioned:

- 1. The CONTRACTOR hereby agrees with the OWNER to commence and complete the construction described as follows:

**Pineview Galvanized Water Main Replacements**

hereinafter called the PROJECT.

- 2. The CONTRACTOR will furnish all of the materials, supplies, tools, equipment, labor, and other services necessary for the construction and completion of the PROJECT described herein.

- 3. The CONTRACTOR will commence the work required by the CONTRACT DOCUMENTS within 10 calendar days after the date of the NOTICE TO PROCEED and will fully complete the PROJECT within 180 consecutive calendar days unless the period for completion is extended otherwise by the CONTRACT DOCUMENTS. The CONTRACTOR further agrees to pay, as liquidated damages, the sum of \$500.00 for each consecutive calendar day thereafter as hereinafter provided in the GENERAL CONDITIONS.

- 4. The CONTRACTOR agrees to perform all of the WORK described in the CONTRACT DOCUMENTS and comply with the terms therein for the sum of \_\_\_\_\_ Dollars (\$ \_\_\_\_\_) or as shown in the Bid Schedule.

- 5. The term "CONTRACT DOCUMENTS" means and includes the following:

- A. Advertisement for Bids
- B. Information for Bidders
- C. Bid
- D. Bid Bond
- E. Agreement
- F. General Conditions
- G. Supplemental Conditions
- H. Performance Bond
- I. Payment Bond
- J. Notice of Award
- K. Notice to Proceed
- L. Change Orders
- M. Drawings prepared by City of Goose Creek Department of Public Works
- N. Specifications prepared by City of Goose Creek Department of Public Works
- O. Addenda

No. \_\_\_\_\_ Dated \_\_\_\_\_  
 No. \_\_\_\_\_ Dated \_\_\_\_\_  
 No. \_\_\_\_\_ Dated \_\_\_\_\_  
 No. \_\_\_\_\_ Dated \_\_\_\_\_

- 6. The OWNER agrees to pay the CONTRACTOR in the manner and at such time as set forth in the General Conditions such amounts as required by the CONTRACT DOCUMENTS.
- 7. This Agreement shall be binding on all parties hereto and their respective heirs, executors, administrators, successors and assigns.

IN WITNESS WHEREOF, the parties hereto have executed or caused to be executed by their duly authorized officials, this Agreement in six counterparts, each of which shall be deemed an original, in the year and day first above written.

City of Goose Creek Department of Public Works  
(OWNER)

(SEAL)

By: \_\_\_\_\_

ATTEST:

\_\_\_\_\_  
(Title of Authorized Official)

\_\_\_\_\_  
(Witness)

\_\_\_\_\_  
(Witness)

\_\_\_\_\_  
(Contractor)

(SEAL)

By: \_\_\_\_\_  
(Name)

ATTEST:

\_\_\_\_\_  
(Title)

\_\_\_\_\_  
(Address)

\_\_\_\_\_  
(Witness)

\_\_\_\_\_  
(Witness)

(End of Section 01210)



**SECTION 01212**

**PERFORMANCE BOND**

KNOW ALL MEN BY THESE PRESENTS: that

\_\_\_\_\_

(Name of Contractor)

\_\_\_\_\_

(Address of Contractor)

a \_\_\_\_\_, hereinafter called Principal and  
(Corporation, Partnership or Individual)

\_\_\_\_\_

(Name of Surety)

\_\_\_\_\_

(Address of Surety)

hereinafter called Surety, are held and firmly bound unto

City of Goose Creek Department of Public Works

(Name of Owner)

200 Button Hall Ave. Goose Creek, SC 29445

(Address of Owner)

hereinafter called OWNER, in the penal sum of \_\_\_\_\_ Dollars,  
(\$\_\_\_\_\_) in lawful money of the United States, for the payment of which sum well  
and truly to be made, we bind ourselves, successors, and assigns, jointly and severally, firmly  
by these presents. THE CONDITION OF THIS OBLIGATION is such that whereas the  
principal entered into a certain contract with the OWNER, dated the \_\_\_ day of \_\_\_\_, 20\_\_\_,  
a copy of which is hereto attached and made a part hereof for the **Pineview Galvanized  
Water Main Replacements.**

NOW, THEREFORE, if the Principal shall well, truly and faithfully perform its duties, all the  
undertakings, covenants, terms, conditions, and agreements, of said contract during the  
original term thereof, and any extensions thereof which may be granted by the OWNER, with  
or without notice to the Surety and during the one year guaranty period (two year guaranty  
period if a building), and if he shall satisfy all claims and demands incurred under such  
contract, and shall fully indemnify and save harmless the OWNER from all costs and  
damages which it may suffer by reason of failure to do so, and shall reimburse and repay the  
OWNER all outlay and expense which the OWNER may incur in making good any default,  
then this obligation shall be void; otherwise to remain in full force and effect.

PROVIDED, FURTHER, that the said Surety for value received hereby stipulates and agrees  
that no change, extension of time, alteration or addition to the terms of the contract or to the  
WORK to be performed thereunder or the SPECIFICATIONS accompanying the same shall  
in any wise affect its obligation of time, alteration, or addition to the terms of the contract or  
to the WORK or to the SPECIFICATIONS. PROVIDED, FURTHER, that no final  
settlement between the OWNER and the CONTRACTOR shall abridge the right of any  
beneficiary hereunder whose claim may be unsatisfied.

IN WITNESS WHEREOF, this instrument is executed in six (6) counterparts, each one of which shall be deemed an original, this the \_\_\_\_\_ day of \_\_\_\_\_, 20 \_\_\_\_.

ATTEST:

\_\_\_\_\_  
Principal

\_\_\_\_\_  
(Principal) Secretary (SEAL)

By: \_\_\_\_\_(S)

\_\_\_\_\_  
Address

\_\_\_\_\_  
Witness as to Principal

\_\_\_\_\_  
Address

WITNESS:

\_\_\_\_\_  
Surety

\_\_\_\_\_  
(Surety)

By: \_\_\_\_\_  
Attorney-in-Fact

(SEAL)

\_\_\_\_\_  
Address

\_\_\_\_\_  
Witness as to Surety

\_\_\_\_\_  
Address

NOTE: Date of BOND must not be prior to date of Contract. If CONTRACTOR is a Partnership, all partners should execute BOND.

IMPORTANT: Surety companies executing BONDS must appear on the Treasury Department's most current list (Circular 570 as amended) and be authorized to transact business in the State of South Carolina.

**SECTION 01214**

**PAYMENT BOND**

KNOW ALL MEN BY THESE PRESENTS: that

\_\_\_\_\_

(Name of Contractor)

\_\_\_\_\_

(Address of Contractor)

a \_\_\_\_\_, hereinafter called Principal and

(Corporation, Partnership or Individual)

\_\_\_\_\_

(Name of Surety)

\_\_\_\_\_

(Address of Surety)

hereinafter called Surety, are held and firmly bound unto

City of Goose Creek Department of Public Works

(Name of Owner)

200 Button Hall Ave Goose Creek, SC 29445

(Address of Owner)

hereinafter called OWNER, in the penal sum of \_\_\_\_\_ Dollars, \$(\_\_\_\_\_) in lawful money of the United States, for the payment of which sum well and truly to be made, we bind ourselves, successors, and assigns, jointly and severally, firmly by these presents. THE CONDITION OF THIS OBLIGATION is such that whereas, the principal entered into a certain contract with the Owner, dated the \_\_\_\_ day of, 20\_\_\_\_, a copy of which is hereto attached and made a part hereof for **Pineview Galvanized Water Main Replacements.**

NOW, THEREFORE, if the Principal shall promptly make payment to all persons, firms, SUBCONTRACTORS, and corporations furnishing materials for or performing labor in the prosecution of the WORK provided for in such contract, and any authorized extension or modification thereof, including all amounts due for materials, lubricants, oil, gasoline, coal and coke, repairs on machinery, equipment and tools, consumed or used in connection with the construction of such WORK, and all insurance premiums on said WORK, and for all labor, performed in such WORK whether by SUBCONTRACTOR or otherwise, then this obligation shall be void; otherwise to remain in full force and effect.

PROVIDED, FURTHER, that the said Surety for value received hereby stipulates and agrees that no change, extension of time, alteration or addition to the terms of the contract or to the WORK to be performed thereunder or the SPECIFICATIONS accompanying the same shall in any wise affect its obligation on this BOND, and it does hereby waive notice of any such change, extension of time, alteration or addition to the terms of the contract or to the WORK or to the SPECIFICATIONS.

PROVIDED, FURTHER, that no final settlement between the OWNER and the CONTRACTOR shall abridge the right of any beneficiary hereunder, whose claim may be unsatisfied.



IN WITNESS WHEREOF, this instrument is executed in six (6) counterparts, each one of which shall be deemed an original, this the \_\_\_\_\_ day of \_\_\_\_\_, 20\_\_.

ATTEST:

\_\_\_\_\_  
Principal

\_\_\_\_\_  
(Principal) Secretary

(SEAL)

By: \_\_\_\_\_(S)

\_\_\_\_\_  
Address

\_\_\_\_\_  
Witness as to Principal

\_\_\_\_\_  
Address

WITNESS:

\_\_\_\_\_  
Surety

(SEAL)

By: \_\_\_\_\_  
Attorney-in-Fact

\_\_\_\_\_  
Address

\_\_\_\_\_  
Witness as to Surety

\_\_\_\_\_  
Address

NOTE: Date of BOND must not be prior to date of Contract. If CONTRACTOR is Partnership, all partners should execute BOND.

IMPORTANT: Surety companies executing BONDS must appear on the Treasury Department's most current list (Circular 570 as amended) and be authorized to transact business in the State of South Carolina.



**SECTION 01215**

**CONTRACTOR'S CERTIFICATION**

---

"I certify by my signature below that I accept the terms and conditions of the \_\_\_\_\_ as required by the \_\_\_\_\_ issued to the owner/operator of the construction activity for which I have been contracted to perform construction related professional services. Further, by my signature below, I understand that I am becoming a co-permittee with the owner/operator and other contractors that have become co-permittees to the general NPDES permit issued to the owner/operator of the facility for which I have been contracted to perform professional construction services. As a co-permittee, I understand that I, and my company, as the case may be, are legally accountable to the SC Department of Health and Environmental Control (DHEC), under the authorities of the CWA and the SC Pollution Control Act, to ensure compliance with the terms and conditions of the \_\_\_\_\_. I also understand that DHEC enforcement actions may be taken against any specific co-permittee or combination of co-permittees if the terms and conditions of the \_\_\_\_\_ are not met. Therefore, having understood the above information, I am signing this certification and am receiving co-permittee status to the aforementioned general NPDES permit."

Date of Signature \_\_\_\_\_

Signature \_\_\_\_\_

Title \_\_\_\_\_

Name of Firm \_\_\_\_\_

Address \_\_\_\_\_

Telephone No. \_\_\_\_\_

In the event the SWPPP is amended by the owner, such amendments should be incorporated to the plan and the contractors and subcontractors should acknowledge by signature.

**CERTIFICATION**

---

Any person signing documents under section 01215 shall also make the following certification:

"I certify under penalty of law that this document and all attachments were prepared under my direction or supervision in accordance with a system designed to assure that qualified personnel properly gathered and evaluated the information submitted. Based on my inquiry of the person or persons who manage the system, or those persons directly responsible for gathering the information, the information submitted is, to the best of my knowledge and belief, true accurate, and complete. I am aware that there are significant penalties for submitting false information, including the possibility of fine and imprisonment for knowing violations."

Date of Signature \_\_\_\_\_

Signature \_\_\_\_\_

Title \_\_\_\_\_

Name of Firm \_\_\_\_\_

Address \_\_\_\_\_

\_\_\_\_\_

Telephone No. \_\_\_\_\_

**NOTICE OF INTENT TO AWARD**

**OWNER:** City of Goose Creek  
(NAME)

**PROJECT:** R-22-1327 Pineview Galvanized Water Main Replacements  
(NUMBER) (NAME)

**TO ALL BIDDERS:**

This is to notify all Bidders that it is the intent of the Owner to award a contract as follows:

**NAME OF BIDDER:** \_\_\_\_\_

**DATE BIDS WERE RECEIVED:** \_\_\_\_\_

**AMOUNT OF BASE BID:** \$ \_\_\_\_\_

**ALTERNATE(S) ACCEPTED: #** \_\_\_\_\_ **Total: \$** \_\_\_\_\_

**TOTAL AMOUNT OF BASE BID WITH ALTERNATE(S):** \$ \_\_\_\_\_

The Owner has determined that the above-named Bidder is responsible and has submitted the lowest responsive Bid. The Owner may enter into a contract with this Bidder subject to the provisions of the law.

**RIGHT TO PROTEST:**

Any actual bidder, offeror, contractor or subcontractor who is aggrieved in connection with the intended award or award of this Contract may protest to the Director of Public Works in accordance with Section 11-35-4210 of the S.C. Code of Laws within 15 days of the date the Notice of Intent to Award is posted.

\_\_\_\_\_  
(PRINT OR TYPE NAME) (AWARDING AUTHORITY TITLE)

\_\_\_\_\_  
(SIGNATURE) (DATE POSTED)

\*\*\*\*\*

**POST A COPY OF THIS FORM AT THE LOCATION ANNOUNCED AT BID OPENING.**

**MAIL TO ALL BIDDERS:** 1. Certified Bid Tabulation (within 10 working days of the bid opening)

**NOTICE OF AWARD**

---

TO: \_\_\_\_\_  
\_\_\_\_\_  
\_\_\_\_\_

**PROJECT DESCRIPTION: Pineview Galvanized Water Main Replacements.**

The OWNER has considered the BID submitted by you for the above-described WORK in response to its Advertisement for Bids dated \_\_\_\_\_, 20\_\_\_\_, and Information for Bidders.

You are hereby notified that your BID has been accepted for items in the amount of \$\_\_\_\_\_

You are required by the Information for Bidders to execute the Agreement and furnish the required CONTRACTOR'S Performance BOND, Payment Bond and certificates of insurance within ten (10) calendar days from the date of this Notice to you.

If you fail to execute said Agreement and to furnish said BONDS within ten (10) days from the date of this Notice, said OWNER will be entitled to consider all your rights arising out of the OWNER'S acceptance of your BID as abandoned and as forfeiture of your BID BOND. The OWNER will be entitled to such other rights as may be granted by law.

You are required to return an acknowledged copy of this NOTICE OF AWARD to the OWNER.

Dated this \_\_\_\_ day of \_\_\_\_\_, 20\_\_\_\_.

City of Goose Creek Department of Public Works  
Owner

By: \_\_\_\_\_

Title: \_\_\_\_\_ Director \_\_\_\_\_

**ACCEPTANCE OF NOTICE**

Receipt of the NOTICE OF AWARD is hereby  
acknowledged by \_\_\_\_\_

this the \_\_\_\_\_ day of \_\_\_\_\_, 20\_\_\_\_.

By \_\_\_\_\_

Title \_\_\_\_\_

**NOTICE TO PROCEED**

---

TO: \_\_\_\_\_ Date: \_\_\_\_\_  
\_\_\_\_\_ Project: Pineview Galvanized  
\_\_\_\_\_ Water Main Replacements

You are hereby notified to commence WORK in accordance with the Agreement dated \_\_\_\_\_, 20\_\_\_\_, on or before \_\_\_\_\_, 20\_\_\_\_, and you are to complete the WORK within 180 consecutive calendar days thereafter. The date of completion of all WORK is therefore \_\_\_\_\_, 20\_\_\_\_\_

City of Goose Creek Department of Public Works  
Owner

By \_\_\_\_\_

Title: Director

ACCEPTANCE OF NOTICE

Receipt of the above NOTICE TO PROCEED is hereby

acknowledged by \_\_\_\_\_

this the \_\_\_\_\_ day of \_\_\_\_\_, 20\_\_\_\_\_

By \_\_\_\_\_

Title \_\_\_\_\_

**SECTION 01220**

**CHANGE ORDER**

---

Order No.: \_\_\_\_\_  
Agreement Date: \_\_\_\_\_

Date: \_\_\_\_\_

NAME OF PROJECT: **Pineview Galvanized Water Main Replacements**

OWNER: City of Goose Creek Department of Public Works

CONTRACTOR: \_\_\_\_\_

The following changes are hereby made to the CONTRACT DOCUMENTS:

Justification:

ITEM

Change to CONTRACT PRICE: \$ \_\_\_\_\_

Original CONTRACT PRICE: \$ \_\_\_\_\_

Current CONTRACT PRICE adjusted by previous CHANGE ORDER: \$ \_\_\_\_\_

The new CONTRACT PRICE due to this CHANGE ORDER will be by: \$ \_\_\_\_\_

Change to CONTRACT TIME:

The CONTRACT TIME will be (increased) (decreased) by \_\_\_\_\_ calendar days.

The date for completion of all work will be \_\_\_\_\_

(Date).

Approvals Required:

ENGINEER: \_\_\_\_\_  
City Engineer

OWNER: \_\_\_\_\_  
Director of Public Works

CONTRACTOR: \_\_\_\_\_



**SECTION 01222**

**REQUEST FOR PAYMENT**

---

CONTRACTOR: \_\_\_\_\_ OWNER: \_\_\_\_\_  
\_\_\_\_\_  
\_\_\_\_\_  
\_\_\_\_\_

REQUEST FOR PAYMENT DATE: \_\_\_\_\_  
TO: \_\_\_\_\_ MONTHLY PAYMENT NO. \_\_\_\_\_  
\_\_\_\_\_  
PROJECT: \_\_\_\_\_  
LOCATION: \_\_\_\_\_  
FOR PERIOD \_\_\_\_\_ TO \_\_\_\_\_

TOTAL VALUE OF WORK COMPLETED TO DATE. \$ \_\_\_\_\_  
(SEE ATTACHED SHEETS)

TOTAL VALUE MATERIALS STORED FOR PROJECT. \$ \_\_\_\_\_  
(SEE ATTACHED SHEETS)

SUB-TOTAL \$ \_\_\_\_\_

DEDUCTIONS: LESS \_\_\_% RETAINED \$ \_\_\_\_\_

LESS PREVIOUS PAYMENTS \$ \_\_\_\_\_

TOTAL AMOUNT DUE THIS PAYMENT \$ \_\_\_\_\_

PREVIOUS PAYMENTS

- |          |          |          |           |
|----------|----------|----------|-----------|
| 1. _____ | 4. _____ | 7. _____ | 10. _____ |
| 2. _____ | 5. _____ | 8. _____ | 11. _____ |
| 3. _____ | 6. _____ | 9. _____ | 12. _____ |

CONTRACTOR'S CERTIFICATION:

I HEREBY CERTIFY THE ABOVE WORK PERFORMED AND MATERIALS STORED ON PROJECT ARE AS PER THE PROVISIONS OF THE CONTRACT AGREEMENT.

CONTRACTOR	APPROVED: ENGINEER	APPROVED: OWNER
BY: _____	BY: _____	BY: _____
DATE: _____	DATE: _____	DATE: _____

ENCLOSURE WITH THIS REQUEST (LIST): \_\_\_\_\_

## SECTION 01230

### GENERAL CONDITIONS

---

#### 1.0 GENERAL

1.1 THE CONTRACT DOCUMENTS: The Contract Documents consist of the Advertisement for Bids, Information for Bidders, Bid, Bid Bond, Agreement, Payment Bond, Performance Bond, Conditions of the Contract (General, Supplemental and Other Conditions), Drawings, Specifications, Addenda, Notice of Award, Notice to Proceed, and Change Orders.

1.2 CORRELATION AND INTENT OF DOCUMENTS: The Contract Documents are complementary, and what is required by anyone shall be as binding as if required by all.

The intent of the Drawings and Specifications to provide a complete and usable facility. The Contractor's work shall be based on the Drawings and Specifications, but the Contractor shall furnish all labor, supplies, materials, tools, machinery, equipment, transportation, supervision, temporary construction of any nature, and all other services, facilities and means necessary to produce a complete and workable facility whether or not such material and appurtenances are shown on the Drawings or described in the Specifications.

Any mention in the Specifications or indication on the Drawings of articles, materials, methods or operations shall require the Contractor to furnish such item or service as if it were fully specified unless it is noted or specified as not in the Contract. It is intended that all materials shall be new and best quality in every respect unless otherwise noted or specified. All workmanship, methods of assembly, and erection shall be first class in every respect.

1.3 CONFLICT OR INCONSISTENCY: If there is any conflict or inconsistency between the provisions of the Supplemental Conditions and the provisions of the other Contract Documents, the provisions of the Supplemental Conditions shall prevail. If there is any conflict or inconsistency between the provisions of the General Conditions and the provisions of any of the Contract Documents, other than the Supplemental Conditions, the provisions of the General Conditions shall prevail.

In case of conflict between the Drawings and Specifications, the Specifications shall govern. Figure dimensions on Drawings shall govern over scale dimensions, and detailed Drawings shall govern over general Drawings. In case of difference between small-scale and large-scale drawings, the large-scale drawings shall govern. Schedules on any contract drawing shall take precedence over conflicting information on that or any other contract drawing.

On any of the drawings where a portion of the work is detailed or drawn out and the remainder is shown in outline, the parts detailed or drawn out shall apply also to all other like portions of the work. Where the word "similar" occurs on the drawings, it shall have a general meaning and not be interpreted as being identical, and all details shall be worked out in relation to their location and their connection with other parts of the work.

Any discrepancies found between the Drawings and Specifications and site conditions or any inconsistencies or ambiguities in the Drawings or Specifications shall be immediately reported to the Engineer, in writing, who shall promptly correct such inconsistencies or ambiguities in writing. Work done by the Contractor after his discovery of such discrepancies, inconsistencies or ambiguities shall be done at the Contractor's risk.

Should a conflict be discovered within the Contract Documents, the Contractor shall be deemed to have estimated the higher quality way of doing the Work unless he shall have asked for and obtained a decision in writing from the Engineer before entering into this Contract.

1.4 ADDITIONAL INSTRUCTIONS AND DETAIL DRAWINGS: The Contractor may furnish additional instructions and detail drawings, by the Engineer, as necessary to carry out the work required by the Contract Documents. The additional drawings and instructions thus supplied will become a part of the Contract Documents. The Contractor shall carry out the work in accordance with the additional detail drawings and instructions.

1.5 SPECIFICATION HEADINGS: For convenience of reference, these Specifications are divided into various Divisions, Sections, Subsections and Paragraphs. The titles of these headings shall not be taken as a correct or complete segregation of the various types of material and labor nor as an attempt to outline jurisdictional procedures. The headings shall not be deemed to limit or restrict the content, meaning or effect of such section, subsection, paragraph, provision or part.

The organization of the Specifications into the various headings, and the arrangement of Drawings shall not control the Contractor in dividing the Work among Subcontractors or in establishing the extent of Work to be performed by any trade. Each subcontract shall be dependent upon its own definite confines, regardless of Divisions of these Specifications. No responsibility, either direct or implied, is assumed by the Owner for omissions or duplications by the Contractor or by any of his subcontractors due to real or alleged errors in arrangement of matter in Contract Documents.

1.6 DRAWINGS AND SPECIFICATIONS FOR CONSTRUCTION PURPOSES: The Contractor will be furnished six (6) complete sets of Drawings and Specifications to be used during the course of construction. If more than six (6) sets are needed, the Contractor will be required to pay the actual cost of printing and handling.

1.7 CONTRACT MODIFICATION: All changes which affect the cost of the construction of the Project must be authorized by means of a contract change order. All change orders and contract modifications must be approved by the Owner prior to becoming effective. The contract change order will include extra work, work for which quantities have been altered from those shown in the bidding schedule as well as decreases or increases in the quantities of installed units which are different from those shown in the bidding schedule because of final measurements. All changes should be recorded on a contract change order as they occur so that they may be included in the partial payment estimate.

1.8 COMPUTATION OF QUANTITIES: For estimating quantities where the computation of areas by geometric methods would be laborious, it is agreed that the planimeter be considered an instrument of precision adapted to the measurement of such areas. It is further agreed that the computation of the volume of prisms shall be by the method of average end areas.

1.9 SIGNS: The Owner reserves the right to all advertising privileges about the job and no signs shall be posted by the Contractor anywhere on the premises without approval by the Owner except those signs, posters, or bulletins required by Federal, State, or local authorities. Directional signs identifying offices and/or storage areas of the Contractor may be erected as required to facilitate work, provided:

1. The Contractor shall submit to the Owner for approval three copies of a scale drawing or sketch of the proposed sign showing size, material, painting.
2. The size of the individual sign shall be not greater than 24 inches wide by 12 inches high.
3. Signs shall be neatly painted on weather-resistant materials.
4. The signs will be removed upon completion of the job.
5. No sign shall be erected prior to approval by the Owner.

1.10 PUBLICITY: All prime contractors and their subcontractors shall submit to the Owner for approval all publicity items, including photographs, relating to the work of this project. Owner shall approve any and all material prior to release for publication.

1.11 DEFINITIONS: Wherever the words hereinafter defined, or pronouns used in their stead occur in the Contract Documents, they shall have the following meanings:

ADDENDA: Written or graphic instruments issued prior to the execution of the Agreement which modify or interpret the Contract Document, Drawings and Specifications by additions, deletions, clarifications or corrections. Such addendum or addenda will take precedent over the position of the general drawings and specifications concerned and will be considered as part of the Contract Documents.

AGREEMENT: The Agreement represents the entire and integrated agreement between the parties hereto and supersedes all prior negotiations, representations or agreements,

either written or oral, including the bidding documents. The Agreement may be amended or modified by a Change Order.

BID: The written offer or proposal of the Bidder, submitted on the prescribed form, properly signed and guaranteed, to perform the work at the prices quoted by the Bidder.

BID BOND: The security furnished by the Bidder with his proposal for the Project is guaranty he will enter into a contract for the work if his proposal is accepted.

BIDDER: Any individual, firm or corporation or combination of same submitting a bid for the work contemplated, acting directly or through a duly authorized representative.

BONDS: Bid, Performance and Payment Bonds and other instruments of security furnished by the Contractor and his Surety in accordance with the Contract Documents.

CALENDAR DAY: Every day shown on the calendar, Sundays and holidays included.

CHANGE ORDER: A written order to the Contractor authorizing an addition, deletion or revision in the Work within the general scope of the Contract Documents or authorizing an adjustment in the Contract Price or Contract Time.

CONSTRUCTION SCHEDULE: A schedule, using an acceptable method, showing the work to be performed in the whole project in relation to the separate parts of the work, the contract time, and the contract costs. The schedule shall be supported by documentation; and weekly or monthly updates may be required to provide documentation as well.

CONTRACT: The Contract Documents form the Contract. The Contract represents the entire and integrated agreement between the parties hereto and supersedes all prior negotiations, representations or agreements, either written or oral, including the bidding documents. The Contract may be amended or modified by a Change Order.

CONTRACT DOCUMENTS: The Contract Documents consist of the Advertisement for Bids, Information for Bidders, Bid, Bid Bond, Agreement, Payment Bond, Performance Bond, the Conditions of the Contract (General, Supplemental, and other Conditions), the Drawings, the Specifications, Addenda issued prior to execution of the Contract, Notice of Award, Notice to Proceed, Change Orders and Supplemental Conditions.

CONTRACT PRICE: The total moneys payable to the Contractor under the terms and conditions of the Contract Documents.

CONTRACTOR: The individual, firm or corporation with whom the Owner has executed the Agreement by which the Contractor is obligated directly, or through Subcontractors, to perform work in connection with the Project. The Contractor is the person or organization identified as such in the Agreement. The term Contractor means the Contractor or his authorized representative.

CONTRACT TIME: The number of calendar days stated in the Contract Documents for the completion of the Work.

DRAWINGS: The part of the Contract Documents showing the characteristics and scope of the Work to be performed and which has been prepared or approved by the Engineer.

EARTH: A material excavated, or to be excavated; all kinds of material other than rock.

ELEVATION: The data on the Drawings or in other Contract Documents after the word "elevation" or its abbreviation shall mean the distance in feet above the defined datum.

ENGINEER: The person, firm or corporation named as such in the Contract Documents and duly appointed by the Owner to undertake the duties and powers herein assigned to the Engineer, acting either directly or through duly authorized representatives.

EQUIPMENT: All machinery, tools, and apparatus, including supplies for upkeep and maintenance, necessary for the proper construction and acceptable completion of the work.

FIELD ORDER: A written order effecting a change in the Work without involving an adjustment in the Contract Price or an extension of the Contract Time and issued by the Engineer to the Contractor during construction.

FURNISH: Furnish and install complete, in place, and ready for use.

INFORMATION FOR BIDDERS: The Notice to Contractors containing all necessary information as to provisions, requirements, date, place, and time of submitting bids.

INCLEMENT WEATHER: Weather affecting the work area severe enough to warrant cessation of all work activities. This includes heavy rain, hail, hurricane, earthquake, freezing rain, heavy fog, tornado, excessive wind gusts, or any other weather condition for which a weather alert, warning or watch is issued, or which affects the project area for more than four hours. Additional time may be afforded for inclement weather.

LATEST EDITION: The current printed document issued eight weeks or more prior to date of receipt of bids.

MATERIALS: Any substance specified for use in the construction of the Project and its appurtenances.

NET COST: The cost to the Contractor after application of all credits and discounts (excepting only cash discounts) and without the addition of any factor for burden, overhead or indirect cost or profit.

NOTICE OF AWARD: The written notice of the acceptance of the Bid from the Owner to the successful Bidder.

NOTICE TO PROCEED: Written communication issued by the Owner to the Contractor authorizing him to proceed with the Work and setting the starting date of the Work.

OPTIMUM MOISTURE CONTENT FOR COMPACTION: The moisture content of a soil calculated on the basis of dry weight of soil at which the soil can be compacted to the approximate maximum density under a specified standard method of compaction.

OWNER: A public or quasi-public body or authority, corporation, association, partnership, or individual for whom the Work is to be performed.

PAYMENT BOND: The approved form of security furnished by the Contractor to guarantee the payment to all persons supplying labor and materials in the prosecution of the work in accordance with the terms of the Contract.

PERFORMANCE BOND: The approved form of security furnished by the Contractor to guarantee the completion of the work in accordance with the terms of the Contract.

PREBID CONFERENCE: A conference usually held one week after the project advertises and before the receipt of bids. At the Prebid Conference, any questions on the plans and specifications can be answered and the Owner and Engineers can explain any areas that specific interpretations have already been made for and items of particular care and interest to the bid. An addendum based on the items discussed will be mailed out to the bidders in attendance.

PRECONSTRUCTION CONFERENCE: A conference following award and prior to start of construction to be attended by a duly authorized representative of the Engineer and by the responsible officials of the Contractor and other affected parties.

PROJECT: The undertaking to be performed as provided in the Contract Documents.

PROPOSAL: The written offer of the Bidder, submitted on the prescribed form, properly signed and guaranteed, to perform the work at the prices quoted by the Bidder.

PROPOSAL FORM: The approved form on which the Owner requires formal bids to be prepared and submitted for the work.

PROPOSAL GUARANTY: The security furnished by the Bidder with his proposal for a Project, as guaranty he will enter into a contract for the work if his proposal is accepted.

PROVIDE: Furnish and install complete, in place, and ready for use.

RESIDENT PROJECT REPRESENTATIVE: The authorized representative of the Owner who is assigned to the Project site or any part thereof.

**ROCK**: A material excavated or to be excavated; only boulders, pieces of concrete or masonry exceeding 1/2 yd<sup>3</sup> in volume, or solid ledge rock which, in the Engineer's opinion requires for its removal drilling and blasting, wedging, sledging, barring, or breaking up with a power-operated tool. (Soft or disintegrated rock which can be removed with hand pick or power-operated excavator or shovel; loose shaken, or previously blasted rock or broken stone in rock fillings or elsewhere; and rock exterior to the maximum limits of measurement allowed, which may fall into the excavation; will not be classified as rock.)

**SHOP DRAWINGS**: All drawings, diagrams, illustrations, brochures, schedules and other data prepared by the Contractor, Subcontractor, manufacturer, Supplier or distributor, which illustrate how specific portions of the Work shall be fabricated or installed.

**SPECIALIST**: An individual or firm of established reputation which is regularly engaged in, and which maintains a regular force of workmen skilled in either manufacturing or fabricating items required by the Contract, installing items required by the Contract, or otherwise performing work required by the Contract. Where the contract specifications require installation by a specialist, that term shall also be deemed to mean either the manufacturer of the item, an individual or firm licensed by the manufacturer, or an individual or firm who will perform the work under the manufacturer's direct supervision.

**SPECIFICATIONS**: A part of the Contract Documents consisting of written descriptions of a technical nature of materials, equipment, construction systems, standards and workmanship.

**STRUCTURES**: Bridges, culverts, catch basins, drop inlets, manholes, cribbing, endwalls, retaining walls, buildings, sewers, service pipes, underdrains, foundation drains, and other miscellaneous items encountered in the work, and not otherwise classified herein.

**SUB-BASE**: The layer or layers of specified or selected material of designated thickness or rate of application placed on a subgrade to comprise a component of the pavement structure to support the base course, pavement or subsequent layer of the construction.

**SUBCONTRACTOR**: An individual, firm or corporation having a direct contract with the Contractor or any other Subcontractor for the performance of a part of the Work at the site. The term Subcontractor means a Subcontractor or his authorized representative.

**SUB-SUBCONTRACTOR**: An individual, firm or corporation having a direct or indirect contract with a Subcontractor to perform any of the Work at the site. The term Sub-subcontractor means a Sub-subcontractor or an authorized representative thereof.

**SUBGRADE**: The maximum depth of normal excavation for a roadbed or building site. The layer upon which the sub-base is placed for a roadbed, or the foundation for a building.

**SUBSTANTIAL COMPLETION**: The date when construction of the Project, or a specific part thereof, is sufficiently completed in accordance with the Contract Documents that it can be used for the purposes for which it is intended. Certified by the Engineer or Owner.



SUPPLEMENTAL CONDITIONS: Contract conditions specific to the type of project.

SUPERINTENDENT: The Contractor's authorized representative in responsible charge of the Work.

SUPPLIER: Any person or company who supplies materials or equipment for the Work, including that fabricated to a special design, but who does not perform labor at the site.

SURETY: The corporation, partnership or individual bound with and for the Contractor for the full and complete performance of the Contract, and for the payment of all debts pertaining to the Work.

TITLES (OR HEADINGS): The titles or headings of the sections and subsections herein are intended for convenience of reference and shall not be considered as having any bearing on their interpretation.

WORK: All labor necessary to produce the construction required by the Contract Documents, and all materials and equipment incorporated or to be incorporated in the Project.

WRITTEN NOTICE: Any notice to any part of the Agreement relative to any part of this Agreement in writing and considered delivered and the service thereof completed, when posted by certified or registered mail to the said party at his last given address or delivered in person to said party or his authorized representative on the Work.

1.12 ADDITIONAL DEFINITIONS: Wherever in the Specifications or on the Drawings, the words "as designated", "as detailed", "as directed", "as ordered", "as permitted", "as prescribed", "as provided", "as requested", "as required", or words of like import are used, it shall be understood that the designation, detail, direction, order, permission, prescription, provision, request or requirement of the Owner or Engineer is intended.

Similarly, the words "approved", "acceptable", "satisfactory", and words of like import shall mean approved by, acceptable to, or satisfactory to the Owner or Engineer.

## **2.0 OWNER'S RIGHTS AND RESPONSIBILITIES**

**2.1 CHANGES IN THE WORK:** The Owner, without invalidating the Contract, may make changes in the Work and in the Drawings and Specifications therefore by making alterations therein, additions thereto, or omissions there from. All work resulting from such changes shall be performed and furnished under and pursuant to the terms and conditions of the Contract. If such changes result in an increase or decrease in the work to be done hereunder, or increase or decrease the quantities thereof, adjustment in compensation shall be made therefore as provided in Subsection **7.12 PAYMENT FOR EXTRA WORK.**

Except in an emergency endangering life or property, no change shall be made unless in pursuance of a written order from the Engineer authorizing the change, and no claim for additional compensation shall be valid unless the change is so ordered.

The Contractor agrees that he shall neither have nor assert any claim for, or be entitled to, any additional compensation for damages or loss of anticipated profits on work that is eliminated.

### **2.2 PROJECT ENGINEER:**

James A. Fisk, P.E.  
City of Goose Creek  
200 Button Hall Ave  
Goose Creek, SC 29445

**2.3 ENGINEER'S AUTHORITY:** The Engineer will be the Owner's representative during the construction period, and he will observe the work in progress on behalf of the Owner. The Engineer will have the authority to act on behalf of the Owner in the following matters consistent with Owner's rights and obligations as set forth in these Contract Documents:

1. Interpretation of Contract Documents.
2. Approval of samples and shop drawings.
3. Preparation of supplementary details and instructions.
4. Inspection and approval of construction work.
5. Preliminary approval of progress payment applications.

Any instructions the Engineer may issue the Contractor are an interpretation of the Contract requirements and not an act of supervision. The Engineer has no authority, nor accepts any responsibility, direct or implied, to direct and superintend the construction operations.

The Contractor shall proceed without delay to perform the work as directed, instructed, determined or decided by the Engineer and promptly comply with such directions, instructions, determinations or decisions. If the Contractor has any objection thereto, he may require that such direction, instruction, determination or decision be put in writing. Within five (5) days after receipt of such writing, he may file a written protest with the Owner, and

simultaneously with the Engineers, stating in clear detail his objections, reasons therefore, and nature and amount of additional compensation, if any, to which he claims he will be entitled thereby. Unless the Contractor files such written protest with the Owner and Engineer within such five (5) day period, he shall be deemed to have waived all grounds for protest of such direction, instruction, decision or determination and all claims for additional compensation or damages occasioned thereby, and shall further be deemed to have accepted such direction, instruction, determination, or decision as being fair, reasonable, and finally determinative of his obligations and rights under the Contract.

2.4 LIABILITY OF OWNER: No person, firm or corporation other than the Contractor, who signed this Contract as such, shall have any interest herein or right hereunder. No claim shall be made or be valid either against the Owner or any agent thereof, and neither the Owner nor any agent thereof shall be liable for or be held to pay any money, except as herein provided. The acceptance by the Contractor of the payment as fixed in the final estimate shall operate as and shall be a full and complete release of the Owner and of every agent of the Owner of and from any and all claims, demands, damages and liabilities of, by or to the Contractor for anything done or furnished for or arising out of or relating to or by reason of the work or for or on account of any act or neglect of the Owner or of any agent of the Owner or of any other person, arising out of, relating to or by reason of the work, except the claim against the Owner for the unpaid balance, if any there be, of the amounts retained as herein provided.

2.5 RIGHTS-OF-WAY AND SUSPENSION OF WORK: The Owner shall furnish all land and rights-of-way necessary for carrying out this Contract and the completion of the Work herein contemplated; and will use due diligence in acquiring said land and rights-of-way as speedily as possible. It is possible that all lands and rights-of-way may not be obtained before construction begins. In this event the Contractor shall begin his work upon such land and rights-of-way as the Owner may have previously acquired. No claim for damages will be allowed whatsoever by reason of delay in obtaining the remaining lands and rights-of-way.

Should the Owner be prevented or enjoined from proceeding with the work, or from authorizing its prosecution, either before or after the commencement, by reason of any litigation, or by reason of its inability to procure any lands or rights-of-way for said work, the Contractor shall not be entitled to make or assert claim for damage by reason of said delay or to withdraw from the Contract except by consent of the Owner; but time for completion of the work will be extended to such time as the Owner determines will compensate for the time lost by such delay, such determination to be set forth in writing.

2.6 SURVEYS, PERMITS AND REGULATIONS: The Owner will furnish all boundary surveys, establish all base lines for locating the principal parts of the Work, and provide a suitable number of benchmarks adjacent to the Work as shown in the Contract Documents.

Encroachment permits, easements for permanent structures and permits for permanent changes in existing facilities shall be secured and paid for by the Owner, unless otherwise specified.

2.7 LINES, GRADES AND MEASUREMENTS: The Engineer will set sufficient base lines and elevations as shown on the Drawings for location of the Work. The Contractor shall employ a registered civil engineer or land surveyor and require them to establish all lines, elevations, reference marks, batter boards, etc., needed by the Contractor during the progress of the work, and from time to time to verify such marks by instrument or other means.

The datum adopted by the Engineer is mean sea level plus 100 feet. All elevations shown on the Drawings or referred to in these specifications refer to this datum. If no elevations are shown, or if notations so state, the elevations shall be considered relative and not absolute.

The Engineer shall be permitted at all times to check the lines, elevations, reference marks, batter boards, etc., set by the Contractor, who shall correct any errors in lines, elevations, reference marks, batter boards, etc., disclosed by such check. Such check shall not be construed to be an approval of the Contractor's work and shall not relieve or diminish in any way the responsibility of the Contractor for the accurate and satisfactory construction and completion of the entire work.

The Engineer shall have access to all field notes and plans. Field notes will be recorded in bound field books, and carbon copies given the Owner's Inspector at the close of each shift.

2.8 OWNER'S RIGHT OF AUDIT: The Owner is to have a full and complete right to audit and make copies of Contractor's or Subcontractor's records with respect to any payment that the Owner may be requested to make, or may make, for any work done on the project. Further, the contractor will furnish all documents necessary for the Owner to obtain a Certified Audit of the entire project.

2.9 OWNER'S RIGHT TO SEPARATE CONTRACTS: The Owner reserves the right to let other contracts in connection with the Work under similar General Conditions. The Contractor shall give other contractors reasonable opportunity to introduce and store their materials and to execute their work and shall properly connect and coordinate his work with theirs.

The Owner may perform additional Work related to the Project by himself, or he may let other contracts containing provisions similar to these. The Contractor will afford other contractors who are parties to such Contracts (or the Owner, if he is performing the additional Work himself), reasonable opportunity for the introduction and storage of materials and equipment and the execution of Work and shall properly connect and coordinate his Work with theirs.

2.10 OWNER'S RIGHT TO DO WORK: If the Contractor should neglect to prosecute the work properly or fail to perform any provision of this Contract, the Owner, after three (3) days' written notice to the Contractor may, without prejudice to any other remedy he may have, make good such deficiencies and may deduct the cost thereof from the payment then or thereafter due the Contractor. If such expense shall exceed the unpaid balance, the Contractor shall pay the difference to the Owner on demand.

The Engineer's certificate of the fair and reasonable cost of repairing, replacing, rebuilding or restoring damaged or defective work or equipment when performed by one other than the Contractor shall be binding and conclusive as to the amount thereof upon the Contractor.

2.11 OWNER'S RIGHT TO TERMINATE CONTRACT: The Owner may, without prejudice to any other right or remedy, and after giving the Contractor and his surety, if any, seven days' written notice, terminate the employment of the Contractor and take possession of the premises and of such materials as it may deem expedient if:

1. Contractor should be adjudged a bankrupt,
2. Contractor should make a general assignment for the benefit of his creditors,
3. A receiver or trustee should be appointed on account of the Contractor's insolvency,
4. Contractor should persistently or repeatedly refuse or fail, except in cases where a time extension is provided, to supply enough properly skilled workmen or proper materials,
5. Contractor fails to promptly pay Subcontractors or suppliers of material or labor,
6. Contractor persistently disregards laws, ordinances or instructions of the Owner and his representatives, or be guilty of substantial violation of any provision of the Contract

In such case, the Contractor shall not be entitled to receive any further payment until the work is finished. If the unpaid balance of the contract exceeds the expense of finishing the work including compensation for additional engineering, managerial and administrative services, such excess shall be paid to the Contractor. If such expense shall exceed such unpaid balance, the Contractor shall pay the difference to the Owner.

2.12 SUSPENSION OF WORK, TERMINATION AND DELAY: The Owner may suspend the Work or any portion thereof for a period of not more than ninety days or such further time as agreed upon by the Contractor, by written notice to the Contractor and the Engineer, which notice shall fix the date on which Work shall be resumed. The Contractor will resume that Work on the date so fixed. The Contractor will be allowed an increase in the Contract Price or an extension of the Contract Time, or both, directly attributable to any suspension.

2.13 INSPECTIONS AND TESTING: If the Contract Documents, Owner's/Engineer's instructions, laws, ordinances or any public authority having jurisdiction require any work to be specially tested or approved, the Contractor shall give the Owner/Engineer timely notice of its readiness for observation by the Owner/Engineer or inspection by another authority and, if

the inspection is by another authority rather than the Owner, of the date fixed for such inspection.

The Contractor shall secure the required certificates of such inspection. Observations by the Owner/Engineer shall be promptly made and, where practicable, at the source of supply. If any work should be covered up without approval or consent of the Owner/Engineer, it must, if required by the Owner/Engineer, be uncovered for examination at the Contractor's expense.

2.14 INSPECTION OF WORK AWAY FROM THE SITE: If the work to be done away from the construction site is to be inspected on behalf of the Owner during its fabrication, manufacture, or testing or before shipment, the Contractor shall give notice to the Engineer of the place and time where such fabrication, manufacture, testing, or shipping is to be done. Such notice shall be in writing and delivered to the Engineer in ample time so that the necessary arrangements for the inspection can be made.

2.15 PRIOR USE OR OCCUPANCY: The Owner reserves the right to use or occupy the Work or portion thereof, and to use equipment installed under the Contract, prior to final acceptance. Such use or occupancy will not constitute acceptance of the Work or any part thereof. Despite such use or occupancy, guarantee periods will not begin until the completion of all work under the Contract, unless the parties agree to the contrary in writing.

2.16 WEATHER CONDITIONS: In the event of temporary suspension of work or during inclement weather or whenever the Engineer shall direct, the Contractor will, and will cause his subcontractors to, protect carefully his and their work and materials against damage or injury from the weather. If in the Engineer's opinion any work or materials have been damaged or injured by the failure on the part of the Contractor or any of his subcontractors to protect its work, such materials shall be removed and replaced at the expense of the Contractor.

2.17 OWNER'S RIGHT TO CLEAN UP: If a dispute arises between the separate contractors as to their responsibility for cleaning up, the Owner may clean up and charge the cost thereof to the Contractor as the Engineer shall determine to be just.

### **3.0 CONTRACTOR'S RIGHTS AND RESPONSIBILITIES**

**3.1 ACCESS TO WORK:** The Owner, Engineer, their officers, agents, and employees, plus representatives of the participating Federal, State, or County agencies may at any and all times and for any and all purposes enter upon the work and site thereof and the premises used by the Contractor, and the Contractor shall at all times provide safe and proper facilities, therefore.

**3.2 WEEKLY PROGRESS MEETINGS:** The Contractor shall hold a brief weekly Progress Meetings with the Owner and Engineer(s), at a place and time acceptable to the Owner.

At the meeting, the Contractor shall present updates to the Schedule of Completion; detail the work progress of the previous week; present a plan of the work to be performed in the current week; discuss any problems with the Work for which the Engineers need to be involved; and present to the Owner any requests for changes in the work, progress, or compensation, therefore.

**3.3 ACCIDENT PREVENTION:** In the performance of the Contract the Contractor shall comply with the applicable provisions of the regulations issued by the Secretary of Labor pursuant to section 107 of the Contract Work Hours and Safety Standards Act entitled "Safety and Health Regulations for Construction" (29 CFR 1518, renumbered as Part 1926). Occupational Safety and Health Standards (29 CFR Part 1910) issued by the Secretary of Labor pursuant to the Williams-Steiger Occupational Safety and Health Act of 1970 are applicable to work performed by the Contractor subject to the provisions of the Act.

**3.4 STATED ALLOWANCES:** The Contractor in the Contract Sum all allowances stated in the Contract Documents. These allowances shall cover the net cost of the materials and equipment delivered and unloaded at the site and all applicable taxes. The Contractor's handling costs on the site, labor, installation costs, overhead, profit and other expenses contemplated for the original allowance shall be included in the Contract Sum and not in the allowance. If the cost, when determined, is more than or less than the allowance, the Contract Sum shall be adjusted accordingly by Change Order which will include additional handling costs on the site, labor, installation costs, overhead, profit and other expenses resulting to the Contractor from any increase over the original allowance.

**3.5 ARCHAEOLOGICAL RIGHTS:** There is a possibility that items of archaeological significance may be found during the excavation of the site. In such event, the Contractor shall stop excavation in the vicinity of the find and notify the Engineer immediately; subsequent excavation work shall proceed as directed by the Engineer. All items found which are considered to have archaeological significance are the property of the Owner.

3.6 AS-BUILT DRAWINGS: The Contractor shall designate one set of Drawings for Field Notes. The Contractor shall indicate on these drawings all field changes affecting the various parts of the work and locations as actually installed. The Contractor shall keep the Field Notes current with the progress of the project.

The Contractor shall hire a registered design professional to produce a stamped set of As-Built Drawings from the Field Notes, and an on-site survey, if necessary. The Contractor shall give the original and five copies of the As-Built Drawings and the Field Notes to the Owner at the beginning of the Final Inspection. After the Final Inspection, the Contractor will receive one set back with corrections marked. The Contractor shall have the design professional correct the Drawings and shall submit an original and five copies to the Owner.

The Final payment, and release of retainage, for the Work will not be made until the As-Built Drawings have been completed and delivered to the Owner.

3.7 SURVEYS, PERMITS AND REGULATIONS: From the information provided by the Owner, unless otherwise specified in the Contract Documents, the Contractor shall develop and make all detail surveys needed for construction such as slope stakes, batter boards, stakes for pile locations and other working points, lines, elevations and cut sheets. The Contractor shall carefully preserve benchmarks, reference points and stakes and, in case of willful or careless destruction, he shall be charged with the resulting expense and shall be responsible for any mistakes that may be caused by their unnecessary loss or disturbance.

The Contractor shall obtain any required state and local permits, licenses, inspections, certificates necessary for the prosecution of the work. The Contractor shall obtain these documents, and pay the fees assessed, for each division of work for which such permits, licenses, and inspections are required. The Contractor shall also obtain and pay the fees for general permits such as Building Permits and Certificates of Occupancy.

The Contractor shall give all notices and comply with all applicable Federal, State and municipal laws, codes, ordinances, rules and regulations bearing on the conduct of the Work as drawn and specified. If the Contractor observes that the Contract Documents are at variance therewith, he shall promptly notify the Engineer in writing, and any necessary changes shall be adjusted as provided in Subsection 2.1 entitled CHANGES IN THE WORK.

3.8 LINES, GRADES AND MEASUREMENTS: The Contractor shall employ at his own expense, a South Carolina Professional Engineer or Land Surveyor who shall be thoroughly experienced in field layout work. Said engineer or surveyor shall establish all lines, elevations, reference marks, etc., needed by the Contractor during the progress of the Work, and from time to time he shall verify such marks by instrument or by other appropriate means.

Alignment and grade of all pipes, tunnels, and borings shall be continuously controlled by use of lasers established through the pipe or casing, not transferred from another medium. The Contractor shall furnish lasers and accessories as required and approved by the Engineer. The



Contractor's Engineer will set and check each laser each day that work is in progress or more often as required to assure continuous accurate control.

The Contractor shall make all measurements and check all dimensions necessary for the proper construction of the work called for by the Drawings and Specifications. During the progress of the Work, he shall make all necessary measurements to prevent misfitting in said work, and he shall be responsible therefore, and for the accurate construction of the entire work.

The Contractor's Engineer responsible for lines and grades shall verify in writing to the Owner that the work has been constructed to lines and grades as shown on the Drawings. This certification shall accompany each request for payment.

**3.9 OBLIGATIONS OF CONTRACTOR:** The Contractor shall and will, in good workmanlike manner, do and perform all work and furnish all supplies and materials, tools, machinery, equipment, transportation, supervision, temporary construction of any nature, and all other services, means and facilities except as herein otherwise expressly specified, necessary or proper to perform and complete all work required by this Contract, within the time herein specified, in accordance with the provisions of this Contract and in accordance with the Drawings and Specifications and in accordance with the direction of the Engineer as given from time to time during the progress of the work. He shall furnish, erect, maintain and remove such construction plant and such temporary works as may be required.

The Contractor shall observe, comply with, and be subject to all terms, conditions, requirements, and limitations of the Contract and Specifications, and shall do, carry on, and complete the entire work to the satisfaction of the Engineer and the Owner.

The Contractor shall check all dimensions, elevations, quantities and instructions shown on the Drawings or given in the Specifications and shall notify the Engineer should any discrepancy of any kind be found in the Drawings, Specifications or conditions at the site. He will not be allowed to take advantage of any discrepancy, error or omission in the Contract Documents. If any discrepancy is discovered, the Engineer will issue full instructions pertaining thereto and the Contractor shall carry out these instructions as if originally specified.

**3.10 CLAIMS FOR ADDITIONAL COST:** If the Contractor wishes to make a claim for an increase in the Contract Sum, he shall give written notice thereof within twenty days after the occurrence of the event giving rise to such claim. This notice shall be given by the Contractor before proceeding to execute the Work, except in an emergency endangering life or property, in which case the Contractor shall proceed in accordance with Subsection 3.28 entitled **PROTECTION OF WORK, PROPERTY AND PERSONS IN AN EMERGENCY**. No such claim shall be valid unless so made. If the Owner and the Contractor cannot agree on the amount of the adjustment in the Contract Sum, it shall be determined by the Engineer. Any change in the Contract Sum resulting from such claim shall be authorized by Change Order.

3.11 CLAIMS FOR DAMAGE: If the Contractor makes claim for any damages alleged to have been sustained by breach of contract or otherwise, he shall, within ten (10) days after occurrence of the alleged breach or within ten (10) days after such damages are alleged to have been sustained, whichever date is the earlier, file with the Engineer a written, itemized statement in triplicate of the details of the alleged breach and the details and amount of the alleged damages. The Contractor agrees that unless such statement is made and filed as so required, his claim for damages shall be deemed waived, invalid and unenforceable, and that he shall not be entitled to any compensation for any such alleged damages. Within ten (10) days after the timely filing of such statement, the Engineer shall file with the Owner one copy of the statement together with his recommendations for action by the Owner.

The Contractor shall not be entitled to claim any additional compensation for damages by reason of any direction, instruction, determination or decision of the Engineer, nor shall any such claims be considered, unless the Contractor shall have complied in all respects with the last paragraph of Subsection 2.3 entitled ENGINEER'S AUTHORITY, including, but not limited to, the filing of written protest in the manner and within the time therein provided.

3.12 CUTTING AND PATCHING: The Contractor shall leave all chases or openings for the installation of his own or any other contractors' or subcontractors' work, or shall cut them in existing work, and shall see that all sleeves or forms are at the work and properly set-in ample time to prevent delays. He shall see that all such chases, openings, and sleeves are located accurately and of proper size and shape and shall consult with the Engineer and the contractors and subcontractors concerned in reference to this work.

In case of his failure to leave or cut all such openings or have all such sleeves provided and set-in proper time, he shall cut them or set them afterwards at his own expense. He shall confine the cutting to the smallest extent possible consistent with the work to be done. In no case shall piers or structural members be cut without the Engineer's written consent and approval.

The Contractor shall carefully fit around, close-up, repair, patch, and point around the work specified herein to the satisfaction of the Engineer.

All of this work shall be done by careful workmen competent to do such work and with the proper small hand tools. Power tools shall not be used except where, in the Engineer's opinion, the type of tool proposed can be used without damage to any work or structure and without inconvenience or interference with the operation of any facility. The Engineer's approval of the type of tool shall not in any way relieve or diminish the responsibility of the Contractor for any damage, inconvenience or interference resulting from the use of such tools.

The Contractor will not cut or alter the work of any subcontractor or any other contractor, nor permit any of his subcontractors to do so except with the written consent of the contractor or subcontractor whose work is to be cut or altered or with the written consent of the Owner or Engineer. All cutting, patching or repairing made necessary by the negligence, carelessness, or incompetence of the Contractor or any of his subcontractors shall be the responsibility of and shall be done at the expense of the Contractor.

3.13 CLEANING UP: The Contractor at all times shall keep the site of the work free from rubbish and debris caused by his operation under the Contract. When the work has been completed, the Contractor shall remove from the site of the work all of his plant, machinery, tools, construction equipment, temporary work and surplus materials so as to leave the work and the site clean and ready for use.

All public streets adjacent to the site and all private ways at the site shall be kept clean of debris, spilled materials, and wet and dry earth at all times and shall be cleaned at the end of each working day. When wet earth is encountered, it shall be cleaned from the vehicles before they leave the site and enter streets and private ways.

3.14 NON-COMPLIANCE WITH CONTRACT REQUIREMENTS: If the Contractor, after receiving written notice from the Owner of non-compliance with any requirement of this Contract, fails to initiate promptly such action as may be appropriate to comply with the specified requirement within a reasonable period of time, the Owner shall have the right to order the Contractor to stop any or all work under the Contract until the Contractor has complied or has initiated such action as may be appropriate to comply within a reasonable period of time. The Contractor will not be entitled to any extension of contract time or payment for any costs incurred as a result of being ordered to stop work for such cause.

3.15 OVERALL PROJECT COORDINATION: The Contractor shall coordinate all Work of his Contract to produce the required finished Project in accordance with the Contract Documents. Special attention shall be given to the submission of shop drawings, samples, color charts, and requests for substitution within the specified time; furnishing the proper shop drawings to Subcontractors and material suppliers, whose work and equipment is affected by and related thereto; and the furnishing of all information concerning location, type, and size of built-in equipment and materials and equipment utilities. This coordination is in addition to all other coordination requirements called for in the technical sections of the Specifications.

3.16 COMMUNICATIONS: The Contractor shall forward all communications to the Owner through the Engineer.

3.17 NO DISCRIMINATION IN EMPLOYMENT: In connection with the performance of work under this Contract, the Contractor agrees not to discriminate against any employee or applicant for employment because of race, religion, color, or national origin. The aforesaid provision shall include, but not be limited to, the following: employment, upgrading, demotion, or transfer; recruitment or recruitment advertising; layoff or termination; rates of pay or other forms of compensation; and selection for training, including apprenticeship.

3.18 DRAWINGS AND SPECIFICATIONS AT THE SITE: The Contractor shall maintain at the site one complete set of all Drawings, Specifications, Addenda, approved Shop Drawings, Change Orders and other Modifications, in good and readable condition and marked to record all changes made during construction. These shall be available to the Engineer. The Drawings, marked to record all changes made during construction, shall be delivered to the Engineer for the Owner upon completion of the work.

3.19 EMPLOY COMPETENT PERSONS: The Contractor shall endeavor to employ only competent persons on the Work. Whenever the Engineer notifies the Contractor in writing that in his opinion any person on the Work is incompetent, unfaithful, disorderly, or otherwise unsatisfactory, or not employed in accordance with the provisions of the Contract, such person shall be discharged from the Work and shall not again be employed on it, except with the written consent of the Engineer. Provided, however, that the failure of the Owner or Engineer to object to an employee is not to be considered acknowledgment or approval of the employee's competence by the Engineer or Owner.

3.20 EMPLOY SUFFICIENT LABOR AND EQUIPMENT: If, in the judgment of the Engineer, the Contractor is not employing sufficient labor, plant, equipment or other means to complete the Work within the time specified, the Engineer may, after giving written notice, require the Contractor to employ such additional labor, plant, equipment and other means as the Engineer may deem necessary to enable the Work to progress properly.

3.21 EXISTING STRUCTURES: Where the dimensions and locations of existing structures are of importance in the installation or connection of any part of the Work, the Contractor shall verify such dimensions and locations in the field before the fabrication of any material or equipment which is dependent on the correctness of such information.

3.22 BENCHMARKS, PROPERTY CORNERS AND MONUMENTS: The Contractor shall maintain, carefully, all benchmarks, property corners, monuments and other reference points encountered. If disturbed or destroyed, the Contractor shall obtain the services of a Registered Land Surveyor to replace them, or pay for the replacement by appropriate authorities, at the Contractors own expense.

3.23 INDEMNIFICATION: The Contractor will indemnify and hold harmless the Owner and the Engineer and their agents and employees from and against all claims, damages, losses and expenses, including attorneys' fees, arising out of or resulting from the performance of the Work, provided that any such claim, damage, loss or expense is attributable to bodily injury, sickness, disease or death, or to injury to or destruction of tangible property including the loss of use resulting there from; and is caused in whole or in part by any negligent or willful act or omission of the Contractor, any Subcontractor, anyone directly or indirectly employed by any of them, or anyone for whose acts any of them may be liable.

In any and all claims against the Owner or the Engineer, or any of their agents or employees, by any employee of the Contractor, any Subcontractor, anyone directly or indirectly employed by any of them, or anyone for whose acts any of them may be liable, the indemnification obligation shall not be limited in any way by any limitation on the amount or type of damages, compensation or benefits payable by or for the Contractor or any Subcontractor under worker's compensation acts, disability benefit acts or other employee benefits acts.

3.24 INTOXICATING LIQUORS: The Contractor shall not sell and shall neither permit nor suffer the introduction or use of intoxicating liquors upon or about the Work.

3.25 LEGAL ADDRESS OF CONTRACTOR: The Contractor's business address and office at or near the site of the Work are both hereby designated as places to which communications may be delivered. The depositing of any letter, notice, or other communication in a postpaid wrapper directed to the Contractor's business address in a post office box regularly maintained by the U. S. Postal Service or the delivery at either designated address of any letter, notice, or other communication by mail or otherwise shall be deemed sufficient service thereof upon the Contractor, and the date of such service shall be the date of deposit. The first-named address may be changed at any time by an instrument in writing, executed and acknowledged by the Contractor and delivered to the Engineer. Service of any notice, letter or other communication upon the Contractor personally shall likewise be deemed sufficient service.

3.26 MUTUAL RESPONSIBILITY OF CONTRACTORS: The Contractor shall afford other contractors' reasonable opportunity to introduce and store their materials / equipment and to execute their work and shall properly connect and coordinate his Work with theirs.

If any part of the Contractor's Work depends for proper execution or results upon the work of any other separate contractor, the Contractor shall inspect and promptly report to the Owner any apparent discrepancies or defects in such work that render it unsuitable for such proper execution and results. Failure of the Contractor so to inspect and report shall constitute an acceptance of the other contractor's work as fit and proper to receive his Work, except as to defects which may develop in the other separate contractor's work after the execution of the Contractor's Work. To ensure proper execution of the subsequent work, the Contractor shall measure work already in place and shall at once report to the Owner any discrepancy between the executed work and the Contract Documents.

Should the Contractor cause damage to any separate contractor on the Work, the Contractor agrees, upon due notice, to settle with such contractor by agreement or arbitration, if he will so settle. If such separate contractor sues the Owner on account of any damage alleged to have been so sustained, the Owner shall notify the Contractor, who shall defend such proceedings at the Contractor's expense, and if any judgment against the Owner arises therefrom, the Contractor shall pay or satisfy it and pay all costs incurred by the Owner.

3.27 WORK HOURS: The Contractor shall maintain a normal work schedule, consisting of five (5) days of eight (8) working hours each or four (4) days of ten (10) working hours each per week. Night, Weekend, and Holiday work will not be permitted unless it meets the requirements of the following section AND has written approval of the Owner.

Work performed by the Contractor at his own volition outside such customary working hours shall be at no additional expense to the Owner.

Any requests received by the Contractor from occupants of existing buildings to change the hours of work shall be referred to the Owner for determination.

3.28 NIGHT AND SUNDAY WORK: No work shall be done at night or on Sunday except:

Usual protective work, such as pumping and the tending of lights and fires;

Work done in case of emergency threatening injury to persons or property;

When provided for under Supplemental Conditions as herein specified;

If all of the conditions set forth in the next paragraph below are met no work other than that included in (1), (2), and (3) above, shall be done at night except when:

- a. In the judgment of the Engineer, the work will be of advantage to the Owner and can be performed satisfactorily at night;
- b. The work will be done by a crew organized for regular and continuous night work;
- c. The Owner has given written permission for such night work.

Any work necessary to be performed after regular hours, on Sundays, or on Legal Holidays shall be performed without additional expense to the Owner.

3.29 OCCUPYING PRIVATE LAND: The Contractor shall not (except after written consent from the proper parties) enter or occupy with men, tools, materials, or equipment, any land outside the rights-of-way or property of the Owner. **A copy of the written consent shall be given to the Engineer prior to occupation of private land.**

3.30 DEWATERING EXCAVATIONS: The Contractor shall remove and dispose of water in all excavations for pipelines, structures, and appurtenances so that construction can be carried out under relatively dry conditions. The dewatering shall be accomplished by the use of pumps, ditches, well points, or other approved methods, as required. Excavations shall be dewatered and brought to the specified grade prior to installation of any permanent structure and shall be maintained in this relatively dry condition throughout project construction.

3.31 PRECAUTIONS DURING ADVERSE WEATHER: During adverse weather and against the possibility thereof, the Contractor shall take all necessary precautions so that the

Work may be properly done and satisfactory in all respects. When required, protection shall be provided by use of tarpaulins, wood and building-paper shelters, or other approved means.

During cold weather, materials shall be preheated if required, and the materials and adjacent structure into which they are to be incorporated shall be made and kept sufficiently warm so that a proper bond will take place and a proper curing, aging or drying will result. Protected spaces shall be artificially heated by approved means that will result in a moist / dry atmosphere according to the particular requirements of the work being protected. Ingredients for concrete and mortar shall be sufficiently heated so that the mixture will warm throughout when used.

The Engineer may suspend construction operations at any time when, in his judgment, the conditions are unsuitable or the proper precautions are not being taken, whatever the weather may be, in any season. The Contractor agrees that he shall not have or assert any claim for or be entitled to any additional compensation or damages on account of any such suspension.

**3.32 PROTECTION OF WORK, PROPERTY AND PERSONS:** The Contractor will be responsible for initiating, maintaining and supervising all safety precautions and programs in connection with the Work. He will take all necessary precautions for the safety of, and will provide the necessary protection to prevent damage, injury or loss to all employees on the Work and other persons who may be affected thereby, all the Work and materials or equipment to be incorporated therein, whether in storage on or off the site, and other property at the site or adjacent thereto, including trees, shrubs, lawns, walks, pavements, roadways, structures and utilities not designated for removal, relocation or replacement in the course of construction.

The Contractor will comply with all applicable laws, ordinances, rules, regulations and orders of any public body having jurisdiction. He will erect and maintain, as required by the conditions and progress of the Work, all necessary safeguards for safety and protection. He will notify owners of adjacent utilities when prosecution of the Work may affect them. The Contractor will remedy all damage, injury or loss to any property caused, directly or indirectly, in whole or in part, by the Contractor, any subcontractor, or anyone directly or indirectly employed by any of them or anyone for whose acts any of them maybe liable, except damage or loss attributable to the acts or omissions of the Owner or the Engineer or anyone employed by either of them or anyone for whose acts either of them may be liable and not attributable, directly or indirectly, in whole or in part, to the fault or negligence of the Contractor.

**3.33 PROTECTION OF WORK, PROPERTY AND PERSONS IN AN EMERGENCY:** In emergencies affecting the safety of persons or the Work or property at the site or adjacent thereto, the Contractor, without special instruction or authorization from the Engineer or Owner, shall act to prevent threatened damage, injury or loss. He will give the Engineer prompt Written Notice of any significant changes in the Work or deviations from the Contract Documents caused thereby, and a Change Order shall thereupon be issued covering the changes and deviations involved.

3.34 PROTECTION AGAINST WATER AND STORM: The Contractor shall take all precautions necessary to prevent damage to the Work by storms or by water entering the site of the Work directly or through the ground. In case of damage by storm or water, the Contractor shall at his own cost and expense make such repairs or replacements or rebuild such parts of the Work as the Engineer may require in order that the finished work may be completed as required by the Contractor.

3.35 PROTECTION OF EXISTING VEGETATION, STRUCTURES, UTILITIES AND IMPROVEMENTS: The Contractor will preserve and protect all existing vegetation such as trees, shrubs, and grass on or adjacent to the site of the work which is not to be removed and which does not unreasonably interfere with the construction work. Care shall be taken in removing trees authorized for removal to avoid damage to vegetation to remain in place. Any limbs or branches of trees broken during such operations or by the careless operation of equipment or by workmen shall be trimmed with a clean cut and painted with a tree pruning compound as approved by the Engineer.

The Contractor will protect from damage all existing improvements or utilities at or near the site of the work, the location of which is made known to him, and will repair or restore any damage to such facilities resulting from failure to comply with the requirements of this Contract or the failure to exercise reasonable care in the performance of the Work. If the Contractor fails or refuses to repair any such damage promptly, the Owner may have the necessary work performed and charge the cost thereof to the Contractor.

The Contractor shall enclose the trunks of trees adjacent to his work and not to be cut with substantial wooden boxes of such height as may be necessary to protect them from injury from piled material, from equipment, from his operation, or otherwise due to his work. Excavating machinery and cranes shall be of suitable type and shall be operated with care to prevent injury to trees not to be cut and particularly to overhanging branches and limbs.

On paved surfaces, the Contractor shall not use or operate tractors, bulldozers or other power-operated equipment, the treads or wheels of which are so shaped as to cut or otherwise injure such surfaces.

3.36 RESTORATION OF PROPERTY: All existing surfaces, including lawns, grassed and planted areas which have been injured by the Contractor's operations, shall be restored to a condition at least equal to that in which they were found immediately before work was begun. Suitable materials and methods shall be used for such restoration. All restored plantings shall be maintained by cutting, trimming, fertilizing, etc., until acceptance. The restoration of existing property or structures shall be done as promptly as practicable and shall not be left until the end of the construction period.

3.37 INTERFERENCE WITH AND PROTECTION OF STREETS: The Contractor shall not close or obstruct any portion of a street, road, or private way without obtaining permits therefore from the proper authorities. If any street, road or private way shall be rendered



unsafe by the Contractor's operations, he shall make such repairs or provide such temporary ways or guards as shall be acceptable to the proper authorities.

The Contractor shall maintain all streets, roads, private ways, and walks not closed in a safe and passable condition and shall assume and have full responsibility for the adequacy and safety of provisions made, therefore.

The Contractor shall notify the Engineer, Highway, Police and Fire Departments at least 24 hours in advance if the closure of a street or road is necessary. He shall cooperate with them in the establishment of alternate routes and shall provide adequate detour signs, plainly marked and well lighted, in order to minimize confusion.

3.38 WORK IN STATE, CITY AND COUNTY RIGHTS-OF-WAY: Attention is directed to the fact that work will be going on in County, City and State rights-of-way. The Owner has obtained permission for the Contractor to encroach on these rights-of-way for work.

The Contractor will be required to conform to the requirements of the South Carolina Department of Transportation, the Berkeley County Public Works Department, and the City of Goose Creek while working within the rights-of-way.

Attention is directed to the fact that existing drainage pipes and ditches will be disturbed during the course of work. Any pipe, which is damaged during construction, shall be replaced with new pipe of the same size and material. Drainage ditches disturbed by the construction are to be graded to drain and grassed upon completion of the construction.

3.39 SCDHEC DISTRICT ENGINEER INSPECTION: All of the work constructed on this project, related to water and sewer lines and appurtenances, is subject to the inspection and approval by the South Carolina Department of Health and Environmental Control District Engineer. This inspection and acceptance are in addition to that of the Engineer.

3.40 EASEMENTS: The Owner has obtained, or will obtain, permanent easements and temporary construction easements through private property. The temporary construction easements entitle the Contractor to the occupancy and use of the designated area near or adjacent to the work for purposes related to the work.

The Contractor will not encroach on any property unless easements have been obtained. On all land, the Contractor has no rights unless he obtains permission from the proper parties.

3.41 TRAFFIC CONTROL: The Contractor will comply with the South Carolina Department of Transportation manual entitled "Traffic Controls for Street and Highway Construction and Maintenance Operations", Part V of the South Carolina Manual on Uniform Traffic Control Devices for Streets and Highways, 2000 and provide traffic control as required and approved by the South Carolina Department of Transportation.

The Contractor shall remove temporary traffic control devices upon completion and acceptance of the work or as their need ceases. Signs shall be used where warranted to maintain traffic or to call attention to conditions on, or adjacent to, the construction work. Such signs shall be removed when they are no longer required.

All traffic control and marking devices shall be in accordance with the provisions of the "State of South Carolina Uniform Manual on Traffic Control Devices". Upon completion and acceptance of the work or as the need for temporary traffic control devices ceases, they shall be removed by the Contractor and shall remain the property of the Contractor.

3.42 DANGER SIGNALS AND SAFETY DEVICES: The Contractor shall make all necessary precautions to guard against damages to property and injury to persons. He shall put up and maintain in good condition, sufficient red or warning lights at night, suitable barricades and other devices necessary to protect the public.

In case the Contractor fails or neglects to take such precautions, the Owner may have lights and barricades installed and charge the cost of this work to the Contractor. Such action does not relieve the Contractor of any liability incurred under this Specification or contract.

3.43 CONSTRUCTION DRAINAGE: The Contractor shall furnish all labor, materials and necessary equipment for the temporary control of surface water and seepage water during construction and keep all excavations, pits and trenches free from water at all times.

The Contractor shall furnish and operate pumps and other equipment required. Dikes and ditches shall be constructed around excavations and elsewhere as necessary to prevent surface water from flooding the excavations or standing in areas adjacent to excavations, in work areas or in material storage areas. The Contractor shall take all necessary precautions to protect adjacent areas and properties at points other than that which would be considered the natural flow, prior to construction, without the expressed consent of the Owner in writing with a copy to the Engineer. He shall take steps to prevent the erosion of soil, earth and other material and the conduction of the eroded materials onto adjacent properties and shall be responsible for the removal of such materials and the restoration of adjacent areas to their original condition.

3.44 RETURN OF DRAWINGS: All copies of Drawings, Specifications and other Documents furnished by the Owner or the Engineer to the Contractor may be used only in connection with prosecution of the Work and shall be returned by the Contractor upon completion of the Work.

3.45 SITE INVESTIGATION: The Contractor acknowledges that he has investigated and satisfied himself as to the conditions affecting the Work, including but not restricted to those bearing upon transportation, disposal, handling and storage of materials, availability of labor, water, electric power, roads and uncertainties of weather, water table, tides or similar physical

conditions at the site, the conformation and conditions of the ground, the character of equipment and facilities needed preliminary to and during prosecution of the Work.

The Contractor further acknowledges that he has satisfied himself as to character, quality and quantity of surface and subsurface materials or obstacles to be encountered insofar as this information is reasonably ascertainable from an inspection of the site, including all exploratory work done by the Owner, as well as from information presented by the Drawings and Specifications made a part of this Contract.

Any failure by the Contractor to acquaint himself with the available information will not relieve him from responsibility for estimating properly the difficulty or cost of successfully performing the work. The Owner assumes no responsibility for any conclusions or interpretations made by the Contractor on the basis of the information made available by the Owner.

**3.46 SOIL EROSION AND SEDIMENT CONTROL:** The Contractor's attention is directed to the fact that unless exposed earth areas are properly cared for during construction, they may result in substantial sedimentation damage downstream from the construction area.

The Contractor shall be responsible for conducting his site grading and drainage operations in such manner as to prevent soil erosion of the construction site work areas. He shall at all times provide satisfactory means to prevent the movement and washing of soil onto pavements or into adjacent ditches, swales, inlets, and drainage pipes, to avoid the possibility of these structures becoming clogged with soil. He shall promptly repair all areas which may become eroded and shall clear drainage ditches, swales, and structures of siltation.

The Contractor will indemnify and hold harmless the Owner and Engineer from and against any and all claims, demands, fines, assessments, including attorneys' fees and cost of defense arising out of or caused by the Contractor's failure to provide soil erosion and sediment control.

**3.47 SUBSURFACE CONDITIONS:** Except in the event of emergency, the Contractor shall promptly and before such conditions are disturbed notify the Owner in writing of:

1. Subsurface or latent physical conditions of the site differing materially from those indicated in the Contract Documents.
2. Unknown physical conditions at the site of an unusual nature, differing materially from those ordinarily encountered and generally recognized as inherent in work of the character provided for in the Contract Documents.

The Owner shall promptly investigate the conditions, and if he finds that such conditions do so materially differ and cause an increase or decrease in the cost of, or in the time required for, performance of the Work, an equitable adjustment shall be made, and the Contract Documents shall be modified by Change Order. Any claim of the Contractor for adjustment hereunder shall not be allowed unless he has given the required Written Notice: provided that the Owner may, if he determines the facts so justify, consider and adjust any such claims asserted before the date of final payment.

3.48 SUBCONTRACTING: The Contractor may utilize the services of specialty Subcontractors on those parts of the Work which, under normal contracting practices, are performed by specialty Subcontractors. The Contractor will, without additional expense to the Owner, utilize the services of specialty subcontractors on those parts of the work which are specified to be performed by specialty subcontractors.

The Contractor shall not award any work to any subcontractor without prior written approval of the Owner, which approval will not be given until the Contractor submits to the Owner a written statement concerning the proposed award to the subcontractor, which statement shall contain such information as the Owner may require. No request for payment will be approved before this list has been received and reviewed by the Owner.

The Contractor shall not award Work to Subcontractor(s) in excess of fifty (50%) percent of the Contract Price without prior written approval of the Owner.

The Contractor will be fully responsible to the Owner for the acts and omissions of his Subcontractors, and of persons either directly or indirectly employed by them, as he is for the acts or omissions of persons directly employed by him.

The Contractor shall cause appropriate provisions to be inserted in all subcontracts relative to the Work to bind Subcontractors to the Contractor by the terms of the Contract Documents insofar as applicable to the Work of Subcontractors and to give the Contractor the same power as regards terminating any subcontract that the Owner may exercise over the Contractor under any provisions of the Contract Documents.

If any other contractor or any subcontractor of any such other contractor shall suffer or claim to have suffered loss, damage or delay by reason of the acts or omissions of the Contractor or of any of his subcontractors, the Contractor agrees to assume the defense against any such claim and to reimburse such other contractor or subcontractor for such loss or damage. The Contractor agrees to and does hereby indemnify and save harmless the Owner from and against any and all claims by such other contractors or subcontractors alleging such loss, damage or delay and from and against any and all claims, demands, costs and expenses, including attorneys' fees, arising out of, relating to or resulting from such claims.

The Contractor shall be responsible for the coordination of the trades, subcontractors, and material men engaged upon his work. The Owner or Engineer will not undertake to settle any differences between the Contractor and his subcontractors or between subcontractors. If any Subcontractor on the project, in the opinion of the Engineer, proves to be incompetent or otherwise unsatisfactory, he shall be replaced if and when directed in writing.

3.49 SUPERVISION: The Contractor shall keep a competent superintendent and assistants on his work during its progress, who shall all be satisfactory to the Owner. **The superintendent shall not be changed except with the consent of the Owner, unless the superintendent proves to be unsatisfactory to the Contractor and ceases to be in his employ.** The

superintendent shall represent the Contractor in his absence and all directions given to him shall be as binding as if given to the Contractor. Important directions shall be confirmed in writing to the Contractor. Other directions shall be so confirmed on written request in each case. The Owner shall not be responsible for the acts or omissions of the superintendent or his assistants.

The Contractor shall give efficient supervision to the Work, using his best skill and attention. He shall carefully study and compare all Drawings, Specifications and other instructions and shall at once report to the Owner any error, inconsistency or omission which he may discover.

3.50 TAXES: The Contractor shall promptly pay federal, state and local taxes which may be assessed against him in connection with the work or his operations under the Agreement and/or the other Contract Documents, including, but not limited to, taxes attributable to the purchase of materials and equipment, to the performance of services, and the employment of persons in the prosecution of the work.

3.51 TEMPORARY HEAT: The Contractor shall provide temporary heat whenever necessary to protect all Work and materials against injury from dampness and cold and to dry out moisture from the building. Fuel, equipment and method of heating shall be satisfactory to the Owner's Insurer and the Engineer.

3.52 TEMPORARY UTILITIES: The Contractor shall make arrangements for and furnish as a part of the Contract, all electricity, water, lighting and other utilities needed to do the Work called for by the Contract. Any separate contractors having a contract with the Owner shall make arrangements for and share the cost with the Contractor for the use of the required utilities on a pro rated schedule based on an agreed basis. All Electrical Work shall comply with the National Electrical Code.

The Contractor shall provide and pay for all temporary wiring, switches, connections and meters. The Contractor shall provide sufficient electric lighting so that all work may be done in a workmanlike manner when there is not sufficient daylight.

3.53 UNCOVERING AND CORRECTION OF WORK: The Engineer shall be furnished by the Contractor with every reasonable facility for examining and inspecting the work and for ascertaining that the work is being performed in accordance with the requirements and intent of the Contract, even to the extent of requiring the uncovering or taking down of portions of finished work by the Contractor.

Should the work thus uncovered or taken down prove satisfactory, the cost of uncovering or taking down and the replacement thereof shall be considered as extra work unless the original work was done in violation of the Contract in point of time or in the absence of the Engineer or his inspector and without his written authorization, in which case said cost shall be borne by the Contractor. Should the work uncovered or taken down prove unsatisfactory, said cost shall likewise be borne by the Contractor.

The inspection of the work shall not relieve the Contractor of any of his obligations to perform and complete the work as required by the Contract. Defective work shall be corrected, and unsuitable materials, equipment, apparatus and other items shall be replaced by the Contractor, notwithstanding that such work, materials, equipment, apparatus and other items may have been previously overlooked or accepted or estimated for payment.

If the work or any part thereof shall be found defective at any time before the final acceptance of the work, the Contractor shall forthwith make good such defect in a manner satisfactory to the Engineer. If any materials, equipment, apparatus or other items brought upon the site for use or incorporation in the work, or selected from the same, are condemned by the Engineer as unsuitable or not in conformity with the Specifications or any of the other Contract Documents, the Contractor shall forthwith remove such materials, equipment, apparatus and other items from the site of the work and shall at his own cost and expense make good and replace the same and any material furnished by the Owner which shall be damaged or rendered defective by the handling or improper installation by the Contractor, his agents, servants, employees or subcontractors.

If the Owner deems it inexpedient to correct work injured or done not in accordance with the Contract, an equitable deduction from the Contract Price shall be made, therefore.

3.54 COOPERATION WITH UTILITIES: The Owner will notify all utility companies, all pipeline owners, or other parties affected, and endeavor to have all necessary adjustments of the public or private utility fixtures, pipelines, and other appurtenances within or adjacent to the limits of construction, made as soon as practicable.

During the course of construction, the Contractor shall maintain in operating condition all active utilities such as gas, electric, telephone, water, sewer, storm drains, etc. encountered in the progress of the Work; and shall repair to the satisfaction of the utility owner any surface, aerial or subsurface utility damage unless such utility is shown to be abandoned or removed.

Water lines, gas lines, wire lines, sewer lines, water and gas meter boxes, water and gas valve boxes, manholes, light standards, cableways, signals, and all other utility appurtenances within the limits of the proposed construction which are to be relocated or adjusted are to be moved by the Owners under separate agreement, except as otherwise noted on the Drawings.

The Drawings will show all known utilities located within the limits of the contract according to information obtained. The accuracy of the Drawings in this respect is not guaranteed by the Owner. The Contractor shall have considered in his bid all of the permanent and temporary utility appurtenances in their present or relocated position. No additional compensation will be allowed for any delays, inconveniences, or damages sustained by him due to any interference from the said utility appurtenances or the operation of moving them.

Unless otherwise provided, the cost of temporary rearrangement of utilities made only in order to facilitate the construction of the work will be borne by the Contractor.

**3.55 WORK WITHIN DRAINAGE DITCH RIGHTS-OF-WAY AND EASEMENTS:**

Attention is directed to the fact that a portion of the project may be constructed within the drainage rights-of-way and easements maintained by the Berkeley County Public Works Department, or the South Carolina Department of Transportation. The Owner has obtained, or will obtain, permission from these agencies to construct within their rights-of-way and easements. The Contractor will be required to conform to the requirements of the Berkeley County Public Works Department or the South Carolina Department of Transportation while working within the drainage rights-of-way or easements.

**3.56 WORK ADJACENT TO TELEPHONE, POWER, GAS COMPANY STRUCTURES:**

Where work is being performed within the telephone company or electric and gas company rights-of-way, the Owner has acquired, or will acquire, permission from these agencies to construct facilities within their rights-of-way or easements. In all cases where work is being performed near telephone company or electric or gas company facilities, the Contractor will notify the respective companies of areas in which work is being performed.

**3.57 WORK BEING PERFORMED NEAR WATER LINES:** The Contractor will inform the proper Water and Sewer Utility of the areas where work is being performed adjacent to or over their water or sewer lines. The Contractor shall co-ordinate with that utility any work that may interfere with their system, including having that utilities inspector on site during any construction that may interfere with or have excavation within three (3) feet of the utility.

**3.58 WORK IN RAILROAD RIGHTS-OF-WAY:** Attention is directed to the fact that work will be going on in railroad rights-of-way. The Owner has obtained permission for the Contractor to encroach on these rights-of-way for work shown on the Drawings.

The Contractor will be required to conform to the requirements of each railroad company while working within the rights-of-way.

The Contractor will contact the Engineer and each railroad company prior to tunneling and open cutting the siding tracks so the work can be fully coordinated with each railroad.

**3.59 UTILITY LOCATIONS:** Prior to beginning any excavation, the Contractor shall comply with South Carolina Code of Laws Title 58 Chapter 35, the Underground Utility Damage Prevention Act, and shall contact P.U.P.S. for an underground utility location; and shall notify all public utility companies not located by P.U.P.S. and have their lines located and marked.

**3.60 VERIFICATION OF DIMENSIONS AND ELEVATIONS:** Dimensions and elevations indicated on the Drawings in reference to existing structures, location of utilities, sewer inverts, or other information on existing facilities, are the best available data obtainable but are not guaranteed by the Engineer. The Engineer will not be responsible for their accuracy. Before proceeding with any work dependent upon the data involved, the Contractor shall field check

and verify all dimensions, grades, inverts, lines, elevations, or other conditions or limitations at the site of the work to avoid construction errors or damage to existing facilities. If any work is performed by the Contractor or any subcontractors prior to adequate verification of applicable data, any resultant extra cost for adjustment of work necessary to conform to existing facilities shall be assumed by the Contractor without reimbursement or compensation by the Owner.

If the Contractor, in the course of the work, finds any discrepancy between the Drawings and the physical conditions of the locality, or any errors or omissions in the Drawings or in the layout as given by survey points and instructions, he shall immediately inform the Engineer, in writing. The Engineer will promptly investigate the reported conditions and issue such instructions as may be necessary for the proper execution of the work. Any work done after such discovery and prior to receipt of such instructions shall be at the risk of the Contractor.



## **4.0 MATERIALS, EQUIPMENT AND WORKMANSHIP**

**4.1 CHEMICAL USAGE:** All chemicals used during construction or furnished for project operation, whether herbicide, pesticide, disinfectant, polymer, reactant or other classification, shall show approval of either EPA or U.S.D.A. The use of all such chemicals and disposal of residues shall be in strict conformance with manufacturer, EPA and U.S.D.A. instructions.

The contractor shall provide the owner with a MSDS for chemicals used at the time such chemicals are delivered to the site for storage or use.

**4.2 CONTRACTOR'S TITLE TO MATERIALS:** No materials or supplies for the Work shall be purchased by the Contractor or by any subcontractor subject to any chattel mortgage or under a conditional sale contract or other agreement by which an interest is retained by the seller. The Contractor warrants that he has good title to all materials and supplies used by him in the Work, free from all liens, claims or encumbrances.

**4.3 CORRECTION OF WORK BEFORE COMPLETION:** The Contractor shall promptly remove from the premises all work condemned by the Owner as failing to conform to the Contract Documents, whether incorporated or not and the Contractor shall promptly replace and re-execute his own work in accordance with the Contract and without expense to the Owner and shall bear the expense of making good all work of other contractors destroyed or damaged by such removal or replacement. The fact that the Engineer may have previously overlooked such defective work shall not constitute an acceptance of any part of it.

If the Contractor does not remove such condemned work within a reasonable time, fixed by written notice, the Owner may remove it, and after storing it at the job site for 30 days, due written notice thereof being given the Contractor, the Owner may offer the material for sale and removal from the premises. Net proceeds from such sale shall be for the Contractor's credit against the "Owner's Right to Do Work". If the material has no sale value, the Owner may remove it from the premises and/or otherwise dispose of it. The costs of such disposition shall be deducted from payments to the Contractor as provided in Subsection 2.10 entitled OWNER'S RIGHT TO DO WORK.

**4.4 CORRECTION OF WORK AFTER COMPLETION:** The Contractor shall remedy any defects due to faulty materials or workmanship and pay for any damage to other work resulting there from which shall appear within a period of one year from the date of final acceptance of the work except where longer periods are specified and in accordance with the terms of any special guarantees provided in the Contract.

**4.5 CORRECTIONS OF WORK AFTER GUARANTEE PERIOD:** It shall be the responsibility of the Contractor to permanently correct all defective items called to his attention

within the guarantee period, whether such correction be made within the guarantee period or not. The Contract shall not be fully performed until such permanent corrections are made.

4.6 GENERAL GUARANTY: The Contractor warrants to the Owner that all materials and equipment furnished under this Contract will be new unless otherwise specified, and that all Work will be of good quality, free from faults and defects and in conformance with the Contract Documents. All Work not so conforming to these standards may be considered defective. If required by the Owner, the Contractor shall furnish satisfactory evidence as to the kind and quality of materials and equipment.

Neither the final certificate of payment, any provision in the Contract Documents nor partial or entire occupancy of the premises by the Owner shall constitute an acceptance of work not done in accordance with the Contract Documents or relieve the Contractor of liability in respect to any express warranties or responsibility for faulty materials or workmanship.

The Contractor shall further guarantee for 24 months any building or buildings constructed under this Project shall be watertight and leak proof at every point in every area, except where leaks can be attributed to damage to the building by external forces other than storm or foundation settlement. He shall immediately, upon notification of water penetration, determine the source of water penetration and at his own expense do any work necessary to make the building watertight. He shall also at his own expense repair or replace any other damaged material to return the building or buildings to the original accepted condition.

In addition to the foregoing stipulations, the Contractor shall comply will all other guarantees and warranties referred to in any portion of the Contract Documents, the more stringent requirement governing. Unless otherwise specifically stated elsewhere in these Specifications, the beginning date of all guarantee or warranty periods is the date of acceptance of the project.

**If for any reason, the Contractor cannot guarantee any part of his work using material or construction methods which have been specified, or shown, he shall notify the Engineer in writing before Contracts are signed, giving reasons together with the name of product and data on substitutions he can guarantee. Should the Contractor fail to so notify the Engineer prior to the signing of Contracts, he will be held to have agreed to guarantee all Work specified of shown.**

4.7 WARRANTY REPAIR WORK: The Contractor shall fully and unconditionally warrant the materials and workmanship of the project for a period of one year, (except buildings, see above), beginning on the date of project completion.

The Contractor shall maintain both the Performance Bond and the Payment Bond in force throughout the one-year warranty period, (or two years, if a building).

The Contractor warrants that he shall investigate, in a sincere, thorough and workmanlike manner, all claims for warranty work within 48 hours of receipt of notice from the Owner of the need for same or existence of deficient parts or portions of the Project. Workmen responding to such notices, shall be skilled craftsmen prepared to perform best quality work. Deficiencies shall be corrected immediately.

The Contractor or his representative shall immediately upon investigation of a notice of deficiency, deliver a report of his findings and corrective actions in writing to the Owner. Failure of the contractor to report his findings in writing within 72 hours of receipt of a warranty claim shall be cause for the Owner to take over and complete the needed warranty work at the Contractor's expense, therefore.

The Contractor warrants that he shall pay all invoices for warranty work performed by the Owner due to his default under this clause. Should the Contractor fail or refuse to pay such invoice rendered by the Owner within 15 days of receipt, the Owner may enter claim with any court of competent jurisdiction for collection of same with interest at the maximum legal rate, together with all associated legal costs and attorney's fees, as a breach of this contract.

**4.8 HANDLING AND DISTRIBUTION:** The Contractor shall handle, haul and distribute all materials and surplus materials on the different portions of the work as necessary or required; shall provide suitable and adequate storage for materials and equipment during the progress of the work; and shall be responsible for the protection, loss of, or damage to materials and equipment furnished by him, until the final completion and acceptance of the work.

The Contractor shall pay storage and demurrage charges to transportation companies and vendors.

**4.9 RIGHT TO MATERIALS:** Nothing in the Contract shall be construed as vesting in the Contractor any right of property in the materials, equipment, apparatus and other items furnished after they have been installed or incorporated in or attached or affixed to the work or the site, but all such materials, equipment, apparatus and other items shall, upon being so installed, incorporated, attached or affixed, become the property of the Owner.

**4.10 STORAGE OF MATERIAL AND EQUIPMENT:** All excavated materials, construction equipment, materials and equipment to be incorporated in the Work shall be placed so as not to injure any part of the Work or existing facilities and so that free access can be had at all times to all parts of the Work and to all public utility installations near of the Work. Materials and equipment shall be kept neatly piled and compactly stored in such locations as will cause a minimum of inconvenience to public travel and adjoining owners, tenants and occupants.

**4.11 MANUFACTURER'S DIRECTIONS:** All manufactured articles, material and equipment shall be applied, installed, connected, erected, used, cleaned and conditioned as directed by the manufacturers, unless herein specified to the contrary.

If the specifications or plans are contrary to the manufacturer's directions, the manufacturer shall be contacted by the Contractor before proceeding with the work and the Engineer advised if the manufacturer has any objections to the specified application.

**4.12 MATERIALS, SERVICES AND FACILITIES:** It is understood that, except as otherwise specifically stated in the Contract Documents, the Contractor shall provide and pay for all labor, supplies and materials, tools, machinery, equipment, transportation, supervision, temporary construction of any nature, and all other services, means and facilities of any nature whatsoever necessary to execute, complete, and deliver the Work within the specified time.

Materials and equipment shall be so stored as to insure the preservation of their quality and fitness for the Work. Stored materials and equipment to be incorporated in the Work shall be located facilitate prompt inspection.

Materials, supplies, and equipment shall be in accordance with samples submitted by the Contractor and approved by the Engineer.

**4.13 MISCELLANEOUS ITEMS:** The work to be done by the Contractor, specified and enumerated under this Contract, shall include any minor details of the Work not specifically mentioned in the Specifications or shown on the Drawings, but obviously necessary for the proper completion of the Work, which shall be considered incidental and as being a part of and included with the Work for which prices are given in the Bid. The Contractor will not be entitled to any additional compensation, therefore.

Miscellaneous items and accessories which are not specifically mentioned but are essential to produce a complete and properly operating installation or usable structure or plant, providing the indicated function, shall be furnished and installed without change in the contract price. Such miscellaneous items and accessories shall be of the same quality standards, including material, style, finish, strength, class, weight and other applicable characteristics as specified for the major component of which the miscellaneous item or accessory is an essential part, and shall be approved by the Engineer before installation. The above requirement is not intended to include major components not covered by or inferable from the Drawings and Specifications.

**4.14 MISTAKES OF CONTRACTOR:** The Contractor shall promptly correct and make good any and all defects, damages, omissions, or mistakes, for which he and/or his agents, servants, employees or subcontractors are responsible, and he shall pay to the Owner all costs, expenses, losses, and damages resulting there from or by reason thereof as determined by the Engineer.

**4.15 PROTECTION AGAINST ELECTROLYSIS:** Where dissimilar metals are used in conjunction with each other, or against concrete surfaces, suitable insulation shall be provided between adjoining surfaces so as to eliminate direct contact and any resultant electrolysis. The insulation shall be bituminous impregnated felt, heavy bituminous coatings, nonmetallic separators or washers, or other approved materials.

4.16 ROYALTIES AND PATENTS: The Contractor shall pay all applicable royalties and license fees. He shall defend all suits or claims for infringement of any patent rights and shall save the Owner harmless from loss on account thereof, except that the Owner shall be responsible for all such loss when a particular process or the product of a particular manufacturer or manufacturers is specified, but if the Contractor has information that the process or article specified is an infringement of a patent, he shall be responsible for such loss unless he promptly gives such information to the Owner in writing.

4.17 SUBMITTAL SCHEDULE: Within ten (10) days after execution and delivery of the Contract, the Contractor shall prepare and deliver to the Engineer a Submittal Schedule. This includes a list of all submittals required under the Contract. The list shall identify each major group of shop drawings, coordination drawings and schedules and each sample and the planned submission date for each.

After the Engineer's review of the list of submittals, the Engineer will meet with the Contractor for a joint review and correction and adjustment, as necessary, for agreement on the submittal. In addition, at the meeting the duration of the review period for each submittal will be established. The Contractor's planned submission date for each submittal shall allow no less than fifteen (15) working days for review and appropriate action before approval of the submittal becomes critical to the progress of the Contractor's work. Within five (5) calendar days after the joint review, the Contractor shall make any necessary revisions to the list of submittals, including durations of the review periods, in accordance with the agreements reached during the joint review and submit two revised copies to the Engineer. No application for partial payment will be approved until the submitted schedule is approved. The Engineer shall not review more than two sets of submittal data (original submittal and one re-submittal) for each item or material without compensation by the Contractor. In the event that additional reviews are required, the Contractor shall compensate the Engineer at the rate of \$ 70.00 per hour for such review.

4.18 SAMPLES: Samples are physical examples furnished by the Contractor to illustrate materials, equipment or workmanship, and to establish standards by which the Work will be judged. It shall be the Contractor's responsibility to furnish samples as required by the technical specifications or as required by the Engineer. These samples must be submitted no later than is required by the Submittal Schedule.

Each sample shall have a label indicating:

- Project Title
- Name of project building or facility
- Name of Contractor
- Name of Subcontractor (if applicable)
- Identification of material with specification section
- Name of producer and brand (if any)

Samples shall be submitted in duplicate unless otherwise noted in the technical specifications and shall be accompanied by a copy of a transmittal letter containing Project Name, Contractor's Name, number of samples, specification section and other pertinent data.

If the Engineer so requires, either prior to or after commencement of the work, the Contractor shall submit samples of materials for such special tests as the Engineer deems necessary to demonstrate that they conform to the Specifications. Such samples shall be furnished, taken, stored, packed and shipped by the Contractor as directed. Except as otherwise expressly specified, the Contractor shall make arrangements for, and pay for, the tests.

All samples shall be packed so as to reach their destination in good condition. To ensure consideration of samples, the Contractor shall notify the Engineer by letter that the samples have been shipped and shall properly describe the samples in the letter. The letter of notification shall be sent separate from and should not be enclosed with the samples.

The Contractor shall submit data and samples, or place his orders, sufficiently early to provide ample time for consideration, inspection, testing, and approval before the materials and equipment are needed for incorporation in the work. The consequences of his failure to do so shall be the Contractor's sole responsibility.

In order to demonstrate the proficiency of workmen, or to facilitate the choice among several textures, types, finishes, surfaces, etc., the Contractor shall provide such samples of workmanship of wall, floor, finish, etc., as may be required.

When required, the Contractor shall furnish to the Engineer triplicate sworn copies of manufacturer's shop or mill tests (or reports from independent testing laboratories) relative to materials, equipment performance ratings, and concrete data.

**4.19 INSPECTION AND TESTING:** All materials and equipment used in the construction of the Project shall be subject to adequate inspection and testing in accordance with generally accepted standards, as required and defined in the Contract Documents.

The Owner shall provide all inspection and testing services not required by the Contract Documents.

The Contractor shall provide at his expense the testing and inspection services required by the Contract Documents.

If the Contract Documents, laws, ordinances, rules, regulations or orders of any public authority having jurisdiction require any Work to specifically be inspected, tested, or approved by someone other than the Contractor, the Contractor will give the Engineer timely notice of readiness. The Contractor will then furnish the Engineer the required certificates of inspection, testing or approval.

Inspections, tests or approvals by the Engineer or others shall not relieve the Contractor from his obligations to perform the Work in accordance with the requirements of the Contract Documents.

The Engineer and his representatives will at all times have access to the Work. In addition, authorized representatives and agents of any participating Federal or State agency shall be permitted to inspect all work, materials, payrolls, records of personnel, invoices of materials, and other relevant data and records. The Contractor will provide proper facilities for such access and observation of the Work and also for any inspection or testing thereof.

If any Work is covered contrary to the specifications in the Contract Documents or the instructions of the Engineer, it must be uncovered for his observation and replaced at the Contractor's expense, when requested by the Engineer.

If the Engineer considers it necessary or advisable that covered Work be inspected or tested by others, the Contractor, at the Engineer's request, will uncover, expose or otherwise make available for observation, inspection or testing as the Engineer may require, that portion of the Work in question, furnishing all necessary labor, materials, tools, and equipment. If it is found that such Work is defective, the Contractor will bear all the expenses of such uncovering, exposure, observation, inspection and testing and of satisfactory reconstruction. If, however, such Work is not found to be defective, the Contractor will be allowed an increase in the Contract Price or an extension of the Contract Time, or both, directly attributable to such uncovering, exposure, observation, inspection, testing and reconstruction and an appropriate Change Order shall be issued.

4.20 SUBSTITUTIONS: The Contractor may recommend the substitution of a material, article or piece of equipment of equal function for those referred to in the Contract Documents by reference to brand name or catalogue number, and if in the Engineer's opinion such material, article, or piece of equipment is of equal function to that specified, the Engineer may approve its substitution and use by the Contractor. Any cost differential shall be deductible from the Contract Price and the Contract Documents shall be appropriately modified by Change Order.

The Contractor warrants that if substitutes are approved, no major changes in the function or general design of the Project will result. Incidental changes or extra component parts required to accommodate the substitute will be made by the Contractor without a change in the Contract Price or Contract Time.

4.21 "OR EQUAL" CLAUSE: The phrase "or equal" shall mean that material or equipment will be acceptable only when in the Engineer's judgment they are composed of parts of equal quality, workmanship and finish and are designed and constructed to perform or accomplish the desired result as efficiently as the indicated brand, pattern, grade, class, make or model.

When a material, article or piece of equipment is identified on the Drawings or in the Specifications by reference to manufacturers' or vendors' names, trade names, catalogue numbers, etc., it is intended merely to establish a standard of quality and function; and any material, article, or equipment of other manufacturers and vendors which will perform adequately the duties imposed by the general design will be considered equally acceptable provided the material, article, or equipment so proposed, is, in the opinion of the Engineer, of

equal substance and function. It shall not be purchased or installed by the Contractor without the Engineer's written approval.

4.22 WAGES AND OVERTIME COMPENSATION: The Contractor and each of his subcontractors shall comply with all applicable State and local laws or ordinances with respect to the hours worked by laborers and mechanics engaged in work on the project and with respect to compensation for overtime.

4.23 NO WAIVER: Neither the inspection by the Owner or the Engineer, nor any order, measurement, approval, determination, decision or certificate by the Engineer, nor any order by the Owner for the payment of money, nor any payment for or use, occupancy, possession or acceptance of the whole or any part of the work by the Owner, nor the extension of time, nor any other act or omission of the Owner or of the Engineer shall constitute or be deemed to be an acceptance of any defective or improper work, materials, or equipment nor operate as a waiver of any requirement or provision of the Contract, or of any remedy, power or right of or herein reserved to the Owner, nor of any right to damages for breach of contract. Any and all rights and/or remedies provided for in the Contract are intended and shall be construed to be cumulative; and, in addition to each and every other right and remedy provided for herein or by law, the Owner shall be entitled as of right to a writ of injunction against any breach or threatened breach of the Contract by the Contractor, by his Subcontractors or by any other person or persons.

4.24 WORK TO CONFORM: During its progress and on its completion, the work shall conform truly to the lines, levels, and grades indicated on the Drawings or given by the Engineer and shall be built in a thoroughly substantial and workmanlike manner, in strict accordance with the Drawings, Specifications, and other Contract Documents and the directions given from time to time by the Engineer.

All work done without instruction having been given therefore by the Engineer, without prior lines or levels, or performed during the absence of the Engineer, will not be estimated or paid for except when such work is authorized by the Engineer in writing. Work so done may be ordered uncovered or taken down, removed, and replaced at the Contractor's expense.



## **5.0 INSURANCE, LEGAL RESPONSIBILITY AND SAFETY**

**5.1 COMPLIANCE WITH LAWS:** The Contract shall be governed by the law of the State of South Carolina. The Contractor shall abide by all local and State Laws or ordinances to the extent that such requirements do not conflict with more stringent Federal laws or regulations. The Contractor shall keep himself fully informed of all existing and future Federal, State and local laws, ordinances, rules and regulations affecting those engaged or employed on the work, the materials and equipment used in the work or the conduct of the work, and of all orders, decrees and other requirements of bodies or tribunals having any jurisdiction or authority over the same, including, but not limited to the U. S. Department of Labor and Bureau of Standards Safety and Health Regulations for Construction and its amendments as set up under the Williams- Steiger Occupational Safety and Health Act of 1970. If any discrepancy or inconsistency is discovered in the Drawings, Specifications or other Contract Documents in relation to any such law, ordinance, rule, regulation, order, decree or other requirement, the Contractor shall forthwith report the same to the Engineer in writing.

The Contractor shall at all times observe and comply with, and cause all his agents, servants, employees, and subcontractors to observe and comply with, all such existing requirements, and he shall protect, indemnify and save harmless the Owner, its officers, agents, servants, and employees from and against any and all claims, demands, suits, proceedings, liabilities, judgments, penalties, losses, damages, costs and expenses, including attorney's fees, arising from or based upon any violation or claimed violation of any such law, ordinance, rule, regulation, order, decree, or other requirement, whether committed by the Contractor or any of his agents, servant employees, or subcontractors.

**5.2 REQUIRED PROVISIONS DEEMED INSERTED:** Each and every provision of law and clause required by law to be inserted in this Contract shall be deemed to be inserted herein, and the Contract shall be read and enforced as though it were included herein. If through mistake or otherwise any such provision is not inserted or is not correctly inserted, then upon the application of either party the Contract shall forthwith be physically amended to make such insertion or correction.

**5.3 LIENS:** If at any time any notice of liens is filed for labor performed or materials or equipment manufactured, furnished, or delivered to or for the Work, the Contractor shall, at its own cost and expense, promptly discharge, remove or otherwise dispose of the same, and until such discharge, removal or disposition, the Owner shall have the right to retain from any moneys payable hereunder an amount which, in its sole judgment, it deems necessary to satisfy such liens and pay the costs and expenses, including attorneys' fees, of defending any actions brought to enforce the same or incurred in connection therewith or by reason thereof.

**5.4 CLAIMS:** If at any time there is any evidence of any claims for which the Contractor is or may be liable or responsible hereunder, the Contractor shall promptly settle or otherwise

dispose of the same, and until such claims are settled or disposed of, the Owner may retain from any moneys which would otherwise be payable hereunder so much thereof as, in its judgment, it may deem necessary to settle or otherwise dispose of such claims and to pay the costs and expenses, including attorneys' fees, of defending any actions brought to enforce such claims or incurred in connection therewith or by reason thereof.

**5.5 PERFORMANCE BOND AND PAYMENT BOND:** Unless otherwise noted in the Supplemental Conditions, a Performance Bond and a Payment Bond are required. The Contractor shall obtain a Performance Bond and Payment Bond, (acceptable to the Owner in a surety company authorized to do business in the state in which the Project is constructed), each for the full amount of the Contract Sum. The bonds shall guarantee the Contractor's faithful performance of the Contract and the payment of all obligations arising thereunder. The bonds shall remain in force until:

1. The Project has been completed and accepted by the Owner;
2. The provisions of all guarantees required by these Contract Documents have been fulfilled or the time limitation for all guarantees has expired; and
3. The time for the filing of all mechanics' liens has expired after which it shall become void.

The Contractor shall pay all charges in connection with the bonds as a part of the Contract. One executed copy of the bonds shall be attached to each copy of the Contract before they are returned to the Engineer for the Owner's signature.

If the Contractor defaults, the Contractor or his Surety shall reimburse the Owner for any additional Engineering fees for additional services made necessary because of said default.

**5.6 ADDITIONAL OR SUBSTITUTE BOND:** If at any time the Owner for justifiable cause, shall be or become dissatisfied with the surety or sureties for the Performance and/or Payment Bonds, the Contractor shall, within 5 days after notice from the Owner to do so, substitute an acceptable bond (or bonds) in such form and sum and signed by such other surety or sureties as may be satisfactory to the Owner. The premiums on such bond shall be paid by the Contractor. No further payments shall be deemed due nor shall be made until the new surety or sureties shall have furnished such an acceptable bond to the Owner.

**5.7 CHANGES NOT TO AFFECT BONDS:** It is distinctly agreed and understood that any changes made in the Work or the Drawings or Specifications therefore (whether such changes increase or decrease the amount thereof or the time required for its performance) or any changes in the manner or time of payments made by the Owner to the Contractor, or any other modifications of the Contract, shall in no way annul, release, diminish or affect the liability of the Surety on the Contract Bonds given by the Contractor, it being the intent hereof that notwithstanding such changes the liability of the Surety on said bonds continue and remain in full force and effect.

5.8 OWNER'S INSURANCE AUTHORITY: During all phases of construction, the Contractor will be required to perform his operations so as to comply expeditiously with the recommendations of the Owner's Insurance Authority.

5.9 ASSIGNMENTS: The Contractor shall not assign the whole or any part of this Contract or any moneys due or to become due hereunder without written consent of the Owner. If the Contractor assigns all or any part of any moneys due or to become due under this Contract, the instrument of assignment shall contain a clause substantially to the effect that it is agreed that the right of the assignee in and to any moneys due or to become due to the Contractor shall be subject to prior claims of all persons, firms, and corporations for services rendered or materials supplied for the performance of the work called for in this Contract.

5.10 INSURANCE: The Contractor shall not commence any work until he obtains, at his own expense, all required insurance (such as Builders Risk for Fire, Theft, Equipment Damage, All Risk, and Flood, Workers Compensation, etc. as required). Such insurance must have the approval of the Owner as to limit, form, and amount. The Contractor will not permit any Subcontractor to commence work on this project until the same insurance requirements have been complied with by such Subcontractor.

The Contractor shall furnish the Owner with certificates showing the type, amount, class of operations covered, effective dates and dates of expiration of policies. Such certificates shall also contain substantially the following statement: "The insurance covered by this certificate will not be canceled or materially altered, except after ten (10) days notice in writing and delivered by registered mail to the Owner." Should any policy be canceled before final payment by the Owner to the Contractor and the Contractor fail immediately to procure other insurance as specified, the Owner reserves the right to procure such insurance and to deduct the cost thereof from any sum due the Contractor under this Contract.

Any insurance bearing on adequacy of performance shall be maintained after completion of the project for the full guaranty period. Should such insurance be canceled before the end of the guaranty period and the Contractor fails immediately to procure other insurance as specified, the Owner reserves the right to procure such insurance and to charge the cost thereof to the Contractor.

Nothing contained in these insurance requirements is to be construed as limiting the extent of the Contractor's responsibility for payment of damages resulting from his operations under this Contract.

The Contractor is required to obtain and maintain for the full period of the Contract the following types of insurance coverage with limits not less than stated below:

A. **BUILDER'S RISK INSURANCE**: The Contractor will procure and maintain, during the life of this Contract, Builder's Risk Insurance (Fire, Extended, All Risk Coverage) on a 100 percent completed value basis on the insurable portion of the

project. The Owner, the Contractor, and Subcontractor (as their interest may appear) shall be named as the Insured.

**B. FLOOD INSURANCE:** The Contractor must acquire any flood insurance made available to it under the National Flood Insurance Act of 1968 as amended beginning with the period of construction and maintain such insurance for the duration of the construction project, if the total value of insurable improvements is \$10,000 or more.

The amount of insurance required is the total project cost, excluding facilities which are uninsurable under the National Flood Insurance Program such as bridges, dams, water and sewer lines, and underground structures, and excluding the cost of the land, or the maximum limit of coverage made available to the grantee under the National Flood Insurance Act, whichever is less.

**C. WORKER'S COMPENSATION INSURANCE:** As required by South Carolina law for all of his employees to be engaged in work at the site of the project under this Contract and, in case of any worker's work sublet, the Contractor shall require the subcontractor similarly to provide Worker's Compensation Insurance for all of the letter's employees to be engaged in such work unless such employees are covered by the protection afforded by the Contractor's Worker's Compensation Insurance. In case any class of employees engaged in hazardous work on the project under this Contract is not protected under the Worker's Compensation Statute, the Contractor shall provide and shall cause each subcontractor to provide adequate employer's liability insurance for the protection of such of his employees as are not otherwise protected.

**D. COMPREHENSIVE GENERAL LIABILITY:**

	Bodily Injury Per Person	Bodily Injury Per Accident	Property Damage
Premises and Operations	1,000,000	1,000,000	1,000,000
Elevator Liability	1,000,000	1,000,000	1,000,000
Contractor's Protective Liability	1,000,000	1,000,000	1,000,000
Products Liability, Including Completed Operations Coverage	1,000,000	1,000,000	1,000,000

**E. COMPREHENSIVE AUTOMOBILE LIABILITY:**

All Owner Automobiles	1,000,000	1,000,000	1,000,000
Non-Owned Automobiles	1,000,000	1,000,000	1,000,000
Hired Car Coverage	1,000,000	1,000,000	1,000,000

**F. SUBCONTRACTOR'S LIABILITY INSURANCE**

Same limits as required of the General Contractor.

**G. RAILROAD INSURANCE**

The Contractor shall procure and maintain in force during the work on railroad property, insurance as described in the following paragraphs. These policies for the

work in and about the railroad company's property shall protect the railroad company from all liability and property damage.

Three certified copies of these policies addressed to the railroad with the endorsements required shall be furnished to and retained by the railroad company involved. No contractor or subcontractor will be permitted to enter upon the railroad properties until such policies and endorsements have been received and approved by the railroad company. The amount of such insurance shall be as follows: Bodily Injury and Property Damage - \$2,000,000 single limit.

The policies issued shall contain endorsements evidencing that any damages resulting from an act or omission of watchman or flag man, or similar employees furnished by the railroad company listed above by reason of the operations of the Owner, the Contractor, or subcontractor shall be deemed a part of the operations of the Contractor and are covered by insurance under said policies.

These policies shall also contain endorsements evidencing that the railroad company mentioned above is protected against any damages arising from injury to officers and employees of the Owner or Contractor or subcontractor while on the premises of the railroad company.

All policies shall contain the following endorsement:

"This policy is not subject to cancellation or change until 30 days after the subject railroad company has received written notice thereof as evidenced by return receipt of registered letter addressed to the railroad company."

**5.11 ORAL AGREEMENTS:** No oral order, objection, claim or notice by any party to the others shall affect or modify any of the terms or obligations contained in any of the Contract Documents, and none of the provisions of the Contract Documents shall be held to be waived or modified by reason of any act whatsoever, other than by a definitely agreed waiver or modification thereof in writing, and no evidence shall be introduced in any proceeding of any other waiver or modification.

**5.12 SAFETY:** In accordance with generally accepted construction practices, the Contractor shall be solely and completely responsible for conditions of the job site, including safety of all persons and property affected directly or indirectly by his operations during the performance of the work. This requirement will apply continuously 24 hours per day until acceptance of the work by the Owner and shall not be limited to normal working hours.

The Contractor shall take all reasonable precautions for the safety of, and shall provide all reasonable protection to prevent damage, injury or loss to:

1. All employees on the Work and all other persons who may be affected thereby;

2. All the Work and all materials and equipment to be incorporated therein, whether in storage on or off the site, under the care, custody or control of the Contractor or any of Subcontractors or Sub-subcontractors; and
3. Other property at the site or adjacent thereto, including trees, shrubs, lawns, walks, pavements, roadways, structures and utilities not designated for removal, relocation or replacement in the course of construction.

The Contractor shall comply with all applicable laws, ordinances, rules, regulations and lawful orders of any public authority having jurisdiction for the safety of persons or property or to protect them from damage, injury or loss. He shall erect and maintain, as required by existing conditions and progress of the Work, all reasonable safeguards for safety and protection, including posting danger signs and other warnings against hazards, promulgating safety regulations and notifying owners and users of adjacent utilities.

When the use or storage of explosives or other hazardous materials or equipment is necessary for the execution of the Work, the Contractor shall exercise the utmost care and shall carry on such activities under the supervision of properly qualified personnel.

The Contractor shall designate a responsible member of his organization at the site whose duty shall be the prevention of accidents. This person shall be the Contractor's superintendent unless otherwise designated in writing by the Contractor to the Owner and the Engineer.

The Contractor shall not load or permit any part of the Work to be loaded so as to endanger its safety.

## **6.0 PROGRESS AND COMPLETION OF WORK**

**6.1 NOTICE TO PROCEED:** Following the execution of the Agreement by the Owner and the Contractor, written Notice to Proceed with the work shall be given by the Owner to the Contractor. The Contractor shall begin and shall prosecute the work regularly and uninterruptedly thereafter (except as provided for herein) with such force as to secure the completion of the work within the Contract Time.

**6.2 CONTRACT TIME:** The Contractor shall complete, in an acceptable manner, all of the work contracted for in the time stated in the Agreement. Computation of Contract Time shall commence the day to be specified in the Notice to Proceed and every calendar day following, except as herein provided, shall be counted as Contract Time.

**6.3 SCHEDULE OF COMPLETION:** At the Pre-Construction Conference, the Contractor shall deliver to the Owner a Schedule of Completion on forms approved by the Owner.

The schedule shall be set up in a Critical Path format, or other method approved by the Owner, and shall be supported by documentation including material and equipment delivery schedules, number and classification of employees to be employed on the Work, list of processes which can be completed simultaneously, or which cannot start until another part is completed, etc.

The schedule shall show the commencement and completion dates of the various subdivisions of work required by the Contract Documents, and all activities required to accomplish the Work. No activity included in the schedule shall have duration greater than FIVE (5) days.

**6.4 PROGRESS SCHEDULE:** The Contractor shall hold a brief weekly Progress Meeting with the Owner and Engineer(s) at a time and place acceptable to the Owner.

At the meeting, the Contractor shall present updates to the Schedule of Completion; detail the work progress of the previous week; present a plan of the work to be performed in the current week; discuss any problems with the work progress for which the Engineer(s) need to be involved; and present to the Owner any requests for changes in the work, progress, or compensation, therefore.

**6.5 WORK CHANGES:** The Owner may, as the need arises, order changes in the work through additions, deletions, or modifications to the extent of 25% of the Contract Amount, without invalidating the Contract. Compensation and time of completion affected by the change shall be adjusted at the time of ordering such change.

**6.6 EXTRA WORK:** New and unforeseen items of work found to be necessary, and which cannot be covered by an item or combination of items for which there is a Contract Price,

shall be classed as Extra Work. The Contractor shall do such Extra Work and furnish such materials as may be required for the proper completion or construction of the whole work contemplated, upon written order from the Owner as approved by the Engineer. In the absence of such written order, no claim for Extra Work shall be considered. Extra Work shall be performed in accordance with these Contract Documents where applicable and work not covered by such shall be done in accordance with the best construction practice and in a workmanlike manner. Extra Work required in an emergency to protect life and property shall be performed by the Contractor as required.

6.7 EXTENSION OF CONTRACT TIME: A delay beyond the Contractor's control occasioned by an Act of God, by act or omission on the part of the Owner or by strikes, lockouts, fire, etc., may entitle the Contractor to an extension of time in which to complete the work as agreed by the Owner, provided, however, that the Contractor shall immediately give written notice to the Owner of the cause of such delay.

Rain days may be granted only if the cumulative rainfall in any day exceeds ½ inch, as measured within two miles of the job site. Days where the rainfall exceeds 1 inch may be granted an additional day for drying out the job site.

Act of God shall mean an earthquake, flood, cyclone or other cataclysmic phenomenon of nature. Rain, wind, flood, or other natural phenomenon of normal intensity for the locality shall not be construed as an Act of God and no reparation shall be made to the Contractor for damage to the Work resulting there from.

All claims for extension of time shall be made in writing to the Engineer no more than twenty days after the occurrence of the delay; otherwise, they shall be waived. In the case of continuing cause of delay only one claim is necessary. Any claim should include complete justification for the extent of the delay claimed.

This Subsection does not exclude the recovery of damages for delay for either party under other provisions of the Contract Documents.

6.8 ENGINEER'S CERTIFICATE OF SUBSTANTIAL COMPLETION: When the work to be performed under this Contract is substantially completed in accordance with the Contract Documents, the Engineer shall prepare an Engineer's Certificate of Substantial Completion to be acknowledged and accepted by the Owner and the Contractor. The Certificate may list items to be completed or corrected but such Certificate shall not relieve the Contractor of his obligation to complete all work, whether listed or not, in accordance with the Contract Documents nor will it preclude any right the Owner may have for recourse in accordance with the Contract Documents.

6.9 TERMINATION OF CONTRACTOR'S RESPONSIBILITY: The Contract will be considered complete when all work has been finished, the final review made up by the



Engineer, and the project accepted in writing by the Owner. The Contractor's responsibility shall then cease, except as set forth in his Performance Bond, as provided in Subsection 4.6 entitled GENERAL GUARANTY, and as provided in Subsection 6.9 entitled CORRECTION OF FAULTY WORK AFTER FINAL PAYMENT.

6.10 CORRECTION OF FAULTY WORK AFTER FINAL PAYMENT: The making of the final payment by the Owner to the Contractor shall not relieve the Contractor of responsibility for faulty materials or workmanship. The Contractor shall promptly replace any such defects discovered within one year, except where longer periods are specified, from the date of written acceptance of the work.

6.11 SCHEDULES, REPORTS AND RECORDS: The Contractor shall submit to the Owner such schedules of quantities and costs, progress schedules, payrolls, reports, estimates, records and other data where applicable as are required by the Contract Documents for the Work to be performed.

The Contractor shall also submit, in a format as approved by the Engineer, a schedule of payments that he anticipates he will earn during the course of the Work.

6.12 ABANDONMENT OF WORK OR OTHER DEFAULT: The Contractor may be declared in DEFAULT of the contract for the following reasons:

If the CONTRACTOR:

1. abandons the work.
2. sublets any part of the work without previous written permission of the OWNER.
3. assigns the contract or any moneys payable hereunder in any manner other than as specified herein.

or, if at any time the Engineer shall be of the opinion, and shall so certify in writing, that:

1. The conditions herein specified as to rate of progress are not being complied with.
2. The work or any part thereof is being unnecessarily or unreasonably delayed.
3. The Contractor has violated or is in default under any of the provisions of the Contract.
4. The Contractor becomes bankrupt or insolvent
5. The Contractor goes or is put into liquidation or dissolution, either voluntarily or involuntarily
6. The Contractor petitions for an arrangement or reorganization under the Bankruptcy Act.
7. The Contractor makes a general assignment for the benefit of creditors or otherwise acknowledges insolvency.

Upon a finding of default by the Contractor, the Owner may notify the Contractor in writing, with a copy of such notice mailed to the Surety, to discontinue such work or any part thereof.

The Contractor shall discontinue such work or part thereof as the Owner may designate; and the Owner may, upon giving notice, by contract or otherwise as it may determine, complete the work or part thereof and charge the entire cost and expense of so completing the work or such part thereof to the Contractor as specified under 2.10: OWNERS RIGHT TO DO WORK.

In addition to the said entire cost and expense of completing the work, the Owner shall be entitled to reimbursement from the Contractor and the Contractor agrees to pay the Owner any losses, damages, costs and expenses, including attorneys' fees, sustained or incurred by the Owner by reasons of any of the foregoing causes.

For the purposes of such completion the Owner may for itself or for any contractors employed by the Owner take possession of any and use or cause to be used any and all materials, equipment, plant, machinery, appliances, tools, supplies and such other items of every description that may be found or located at the site of the Work. No equipment or materials may be removed from the Work without the written consent of the Owner.

All costs, expenses, losses, damages, attorneys' fees and any and all other charges incurred by the Owner under this Subsection shall be charged against the Contractor and deducted and/or paid by the Owner out of any moneys due or payable or to become due or payable to the Contractor under the Contract.

In computing the amounts chargeable to the Contractor, the Owner shall not be held to a basis of the lowest prices for which the completion of the work or any part thereof might have been accomplished; but all sums actually paid or obligated therefore to affect its prompt completion shall be charged to and against the account of the Contractor.

In case the costs, expenses, losses, damages, attorney's fees and other charges together with all payments there-to-fore made to or for the account of the Contractor are less than the sum which would have been payable under the Contract if the work had been properly performed and completed by the Contractor, the Contractor shall be entitled to receive the difference.

In case such costs, expenses, losses, damages, attorneys' fees and other charges, together with all payments there-to-fore made to or for the account of the Contractor, shall exceed the said sum, the Contractor shall pay the amount of the excess to the Owner.

6.13 FINAL INSPECTION: When the work has been completed in accordance with the Contract, the Contractor shall notify the OWNER in writing, and request a final inspection. At the Final Inspection the Contractor shall give the Owner the As-Built Drawings, See §3.6.

The Owner and Engineer shall jointly review the work after they are satisfied that all work has been substantially completed in accordance with the contract documents and change orders.

A "Punch List" shall be made of all deviations from the Contract requirements and a copy of such list furnished to the Contractor. The Contractor shall with reasonable haste remedy all defects so noted and shall notify the Owner upon the completion of such work.

When inspection by the Owner's authorized representatives shows the work to be complete in accordance with the Contract, application for final payment may be made.

After project completion, funds may be withheld from the Contractor only if they are required to insure specific performance of deficient portions of the contract. The contractor shall be required to provide a representative for all work reviews and regulatory agency inspections. Work noted as requiring the attention of the Contractor, after satisfaction of the "Final Punch List" shall be considered as warranty work.

## **7.0 PAYMENTS TO THE CONTRACTOR**

**7.1 PRICES FOR WORK:** The Owner shall pay, and the Contractor shall receive the prices stipulated in the Bid made a part hereof as full compensation for everything performed and furnished and for all risks and obligations undertaken by the Contractor under and as required by the Contract.

**7.2 SCHEDULE OF VALUES:** Except in cases where unit prices form the basis for payment under the Contract, the Contractor shall, within twenty (20) days of the execution of the Contract and not less than ten (10) days prior to making an application for partial payment, submit to the Owner in a form approved by the Owner a schedule of values showing a breakdown of the Contract Sum itemized by trade and/or specification sections or as otherwise directed by the Owner and for each item shall show the total value including the Contractor's overhead and profit. Upon approval by the Owner, this schedule will be used in determining the value of the work done for the purpose of partial payments.

The costs employed in making up any of these schedules will be used only for determining the basis of partial payments and will not be considered as fixing a basis for additions to or deductions from the Contract Price.

**7.3 APPLICATIONS FOR PARTIAL PAYMENT:** Before the first day of each month, or as otherwise directed by the Owner, the Contractor shall make applications for the value of the work done and the materials installed and/or delivered to the site for installation in the project during the previous month.

Such applications shall show the breakdown of the project into the same items as the schedule of values specified in Subsection 7.2 entitled SCHEDULE OF VALUES, and showing for each item the total value, the value previously reported as complete, the value completed during the month, the cumulative value completed and the value remaining to be done.

The application shall also show the value of materials delivered to the site which have not been incorporated into the work and whose value is not included in the amount shown for the work of which they are a part. The value of such materials shall be established by attaching copies of invoices covering the materials to the application.

The application shall include a summary of value of the work performed during the previous month, plus the value of the material delivered to the job site but not incorporated in the work, and minus the amount of the retainage indicated in Subsection 7.4 entitled RETAINAGE.

The Engineer will, within five (5) days after receipt of each partial payment estimate, either indicate in writing his approval of payment and present the partial payment estimate to the Owner, or return the partial payment estimate to the Contractor indicating in writing his

reasons for refusing to approve payment. In the latter case, the Contractor may make the necessary corrections and resubmit the partial payment estimate.

7.4 RETAINAGE: The Owner shall retain ten (10) percent of the amount of each payment until final completion and acceptance of all work covered by the Contract Documents. The Owner at any time, however, after fifty (50) percent of the work has been completed, if he finds that satisfactory progress is being made, may make further partial payments in full on the current and remaining estimates, but amounts previously retained shall not be paid to the Contractor at fifty (50) percent completion.

Any time thereafter, when, in the opinion of the Engineer, the progress of the Work is not satisfactory, additional amounts may be retained but in no event shall the total retainage be more than ten (10) percent of the value of the work completed. Upon substantial completion of the work, any amount retained may be paid to the Contractor.

When the Work has been substantially completed except for Work which cannot be completed because of weather conditions, lack of materials or other reasons which in the judgment of the Owner are valid reasons for non-completion, the Owner may make additional payments, retaining at all times an amount sufficient to cover the estimated cost of the Work still to be completed.

7.5 PAYMENTS WITHHELD: The Owner may withhold payment or, on account of subsequently discovered evidence, nullify the whole or part of any application to the extent necessary to protect himself from loss on account of:

1. Defective work not remedied;
2. Claims filed or reasonable evidence indicating the probable filing of claims;
3. The Contractor's failure to pay Subcontractors, material suppliers, or employees;
4. A reasonable doubt that the Contract work can be completed for the balance unpaid; or
5. Damage to another Contractor.

When the above grounds are removed, payment will be made for the amounts withheld because of them.

7.6 PAYMENT OF APPLICATIONS FOR PARTIAL PAYMENT: Upon verification and approval of the application for partial payment made as specified, the Owner will make payment of the amount found properly due. No payment made to the Contractor, nor partial or entire use or occupancy of the Work by the Owner shall be an acceptance of any work or materials not in accordance with this Contract.

7.7 RELEASE OF LIENS: Neither the final payment nor any part of the retained percentage shall become due until the Contractor shall deliver to the Owner a complete and notarized

release of all liens arising out of this Contract, or receipts in full in lieu thereof. If required, the Contractor shall submit an affidavit that to his knowledge the releases and receipts include all the labor and material for which a lien could be filed; but the Contractor may if any Subcontractor refuses to furnish a release or receipt in full furnish a bond satisfactory to the Owner to indemnify him against any lien. If any lien remains unsatisfied after all payments are made the Contractor shall refund to the Owner all moneys that the latter may be compelled to pay in discharging such a lien including all costs and reasonable attorneys' fees.

7.8 USE OR PARTIAL PAYMENT NOT ACCEPTANCE: It is agreed that this is an entire contract for one whole and complete work or result and that neither the Owner's entrance upon nor use of the Work or any part thereof nor any partial payments by the Owner shall constitute an acceptance of the Work or any part thereof before its entire completion and final acceptance.

7.9 PAYMENT FOR UNCORRECTED WORK: Should the Owner direct the Contractor not to correct work that has been damaged or that was not performed in accordance with the Contract Documents, an equitable deduction from the Contract Amount shall be made to compensate the Owner for the Uncorrected Work.

7.10 PAYMENT FOR REMOVAL OF REJECTED WORK AND MATERIALS: The removal of work and materials rejected in accordance with Subsection 4.3 entitled CORRECTION OF WORK BEFORE COMPLETION and the re-execution of acceptable work by the Contractor shall be at the expense of the Contractor, and he shall pay the cost of replacing the work of other contractors destroyed or damaged by the removal of the rejected work or materials and the subsequent replacement of acceptable work.

Removal of rejected work or materials and storage of materials by the Owner, in accordance with Subsection 4.3 entitled CORRECTION OF WORK BEFORE COMPLETION, shall be paid by the Contractor within thirty (30) days after written notice to pay is given by the Owner. If the Contractor does not pay the expenses of such removal and after ten (10) days' written notice being given by the Owner of his intent to sell the materials, the Owner may sell the materials at auction or at private sale and will pay the Contractor the net proceeds therefrom after deducting all the costs and expenses that should have been borne by the Contractor.

7.11 PAYMENT FOR EXTRA WORK: Written notice of claims for payment for Extra Work shall be given by the Contractor within ten days after receipt of instructions from the Owner to proceed with the Extra Work and also before any work is commenced, except in emergency endangering life or property. No claim shall be valid unless so made. In all cases, the Contractor's itemized estimate sheets showing all labor and material shall be submitted to the Owner. The Owner's order for Extra Work shall specify any extension of the Contract Time and one of the following methods of payment:

1. Unit price or combinations of unit prices which form the basis of the original Contract.
2. A lump sum based on the Contractor's estimate and accepted by the Owner.
3. Net cost plus a fixed fee. Net costs are defined as follows:
  - 3.1 Labor costs, including time of foreman while engaged directly upon extra work at rates not greater than the scale of rates for each respective classification of labor customary in the area where the work is performed for each respective job classification.
  - 3.2 Labor, insurance, and taxes, including amounts paid on a percent of such labor rates or on a cents per hour basis for Worker's Compensation, Public Liability, Contractor's Contingent Liability and Contractual Liability Insurance and all Federal Old Age and Unemployment Taxes and any other taxes applicable as well as fringe benefits as may be approved by the Engineer.
  - 3.3 Materials and supplies actually used on the work.
  - 3.4 Rental charges for necessary equipment, as agreed upon by the Owner and Contractor. Rental charges shall not exceed those published in Rental Rates for Construction Equipment issued by the American Equipment Distributor. Equipment and tools having a value of \$100.00 or less are considered to be "small tools" and, as such are considered to be part of overhead.

To the cost under (3) there shall be added a fixed fee to be agreed upon but not to exceed fifteen (15) percent of the estimated cost of the work. The fee shall be compensation to cover the cost of supervision, overhead, bond, profit and any other general expenses. On work performed by subcontractors, the fixed fee shall not exceed five (5) percent of the cost of the work.

7.12 PAYMENT FOR WORK SUSPENDED BY THE OWNER: If the work or any part thereof shall be suspended by the Owner and abandoned by the Contractor as provided in Subsection 2.12 entitled SUSPENSION OF WORK, TERMINATION AND DELAY, the Contractor will then be entitled to payment for all work done on the portions so abandoned.

7.13 PAYMENT FOR WORK BY THE OWNER: The cost of the work performed by the Owner, in accordance with Subsection 2.10 entitled OWNER'S RIGHT TO DO WORK, shall be paid by the Contractor.

7.14 PAYMENT FOR WORK BY THE OWNER FOLLOWING TERMINATION OF CONTRACT BY OWNER: Upon termination of the Contract by the Owner in accordance with Subsection 2.11 entitled OWNER'S RIGHT TO TERMINATE CONTRACT, no further payment shall be due the Contractor until the work is completed. If the unpaid balance of the Contract Amount shall exceed the cost of completing the work including all overhead costs,

the excess shall be paid to the Contractor. If the cost of completing the work shall exceed the unpaid balance, the Contractor shall pay the difference to the Owner. The cost incurred by the Owner, as herein provided, and the damage incurred through the Contractor's default shall be certified by the Owner.

7.15 PAYMENT FOR SAMPLES AND TESTING OF MATERIALS: Samples furnished in accordance with Subsection 4.18 entitled SAMPLES shall be furnished by the Contractor at his expense.

Testing of samples and materials furnished in accordance with Subsection 4.18 entitled SAMPLES shall be arranged and paid for by the Owner.

7.16 ACCEPTANCE AND FINAL PAYMENT: When the Contractor shall have completed the work in accordance with the terms of the Contract Documents, he shall certify completion of the work to the Owner and submit a final Request for Payment. This request shall be the Contract Amount plus all approved additions, less all approved deductions, less previous payments made.

The Contractor shall furnish evidence that he has fully paid all debts for labor, materials, and equipment incurred in connection with the work. Upon acceptance, the Owner will release the Contractor (except as to the conditions of the Performance Bond and the Payment Bond, any legal rights of the Owner, required guaranties, and Correction of Faulty Work after Final Payment), and will pay the Contractor's final Request for Payment.

The Contractor will allow enough time for the Engineer to assemble and check the necessary data.

The Contractor shall deliver to the Owner a complete release of all liens arising out of this Contract before the retained percentage or before the final Request for Payment is paid.

7.17 ACCEPTANCE OF FINAL PAYMENT AS RELEASE: The acceptance by the Contractor of final payment shall be and shall operate as a release to the Owner of all claims and all liability to the Contractor other than claims in stated amounts as may be specifically excepted by the Contractor for all things done or furnished in connection with this Work and for every act and neglect of the Owner and others relating to or arising out of this Work. Any payment, however, final or otherwise, shall not release the Contractor or his sureties from any obligations under the Contract Documents or the Performance Bond and the Payment Bond.

7.18 DELAYS AND DAMAGES: The date of beginning and the time for completion of the Work are essential conditions of the Contract Documents and the Work embraced shall be commenced on a date specified in the Notice to Proceed.



The Contractor will proceed with the Work at such rate of progress to insure full completion within the Contract Time. It is expressly understood and agreed by and between the Contractor and the Owner that the Contract Time for the completion of the Work described herein is a reasonable time, taking into consideration the average climatic and economic conditions and other factors prevailing in the locality of the Work.

If the Contractor refuses or fails to prosecute the Work, or any separable part thereof, with such diligence as will ensure its completion within the time specified in the Contract, or any extension thereof, or fails to complete said Work within such time, the Owner may, by written notice to the Contractor and his Surety, terminate his right to proceed with the Work or such part of the work as to which there has been delay.

In such event the Owner may take over the Work and prosecute the same to completion, by contract or otherwise, and may take possession of and utilize in completing the work such materials, appliances, and plant as may be on the site of the work and necessary, therefore.

Whether or not the Contractor's right to proceed with the Work is terminated, he and his sureties shall be liable for any damage to the Owner resulting from his refusal or failure to complete the Work within the specified time.

If fixed and agreed liquidated damages are provided in the Contract and if the Owner so terminates the Contractor's right to proceed, the resulting damage will consist of such liquidated damages until such reasonable time as may be required for final completion of the Work together with any increased costs occasioned by the Owner in completing the Work.

If fixed and agreed liquidated damages are provided in the Contract, and if the Owner does not so terminate the Contractor's right to proceed, the resulting damage will consist of such liquidated damages until the Work is completed or accepted.

The Contractor's right to proceed shall not be so terminated nor the Contractor charged with resulting damage if:

1. The delay in the completion of the Work arises from unforeseeable causes beyond the control and without the fault or negligence of the Contractor, including but not restricted to, Acts of God, acts of the public enemy, acts of the Government in either its sovereign or contractual capacity, acts of another contractor in the performance of a contract with the Owner, fires, floods, epidemics, quarantine restrictions, strikes, freight embargoes, unusually severe weather, or delays of subcontractors or suppliers arising from unforeseeable causes beyond the control and without the fault or negligence of both the Contractor and such subcontractors or suppliers; and
2. The Contractor, within ten (10) days from the beginning of any such delay (unless the Owner grants a further period of time before the date of final payment under the Contract), notifies the Owner in writing of the causes of delay.

As used in subparagraph 1, above, the term "subcontractors or suppliers" means subcontractors or suppliers at any time.

The Engineer shall ascertain the facts and the extent of the delay and extend the time for completing the Work when, in his judgment, the findings of fact justify such an extension, and his findings of fact shall be final and conclusive on the parties, subject only to appeal as provided in these General Conditions.

The rights and remedies of the Owner provided in this clause are in addition to any other rights and remedies provided by law or under this Contract.

(End of Section 01230)

1. CONFLICT OF INTEREST: No official of the Owner who is authorized in such capacity and on behalf of the Owner to negotiate, make, accept or approve, or to take part in negotiating, making, accepting, or approving any architectural, engineering, inspecting, construction, or material supply contract, or any subcontract in connection with the construction of the Project, shall become directly or indirectly interested personally in this Contract or in any part thereof. No officer, employee, architect, attorney, engineer, or inspector of or for the Owner who is authorized in such capacity and on behalf of the Owner who is in any legislative, executive, supervisory, or other similar functions in connection with the construction of the Project, shall become directly or indirectly interested personally in this Contract or in any part thereof, any material supply contract, subcontract, insurance contract, or any other contract pertaining to the project.

2. LIMITS OF NORMAL EXCAVATION: In determining the quantities of excavation to which unit prices shall apply, the limits of normal width and depth of excavation shall be as described below, unless other limits are indicated on the Drawings or specified.

For pipes in trenches, the normal width of the trench shall be measured between vertical planes which are a distance apart equal to the sum of 18 inches plus 1-1/3 times the nominal inside diameter of the pipe. If the width so computed is less than 3 feet, a width of 3 feet shall be taken as the normal width for payment. The normal depth shall be measured to a distance of 0.2 foot below the bottom of the pipe in earth and 0.7 foot in rock, unless there be a cradle underneath the pipe; in which case the normal depth shall be measured to the underside of the cradle. The width of trench for the cradle shall be assumed to be that specified above for pipes in trenches.

For concrete placed directly against undisturbed earth, the normal width and depth of the excavation for such concrete shall be measured to the neat lines of the concrete as indicated on the Drawings or as ordered.

For concrete placed against rock surfaces resulting from rock excavation, the normal width and depth of the excavation shall be measured to 0.4 foot outside the neat lines of the concrete as indicated on the Drawings or as ordered.

For other structures, except manholes as noted below, the normal width shall be measured between vertical planes 1 foot outside the neat lines of the several parts of the structure, except that the width at any elevation shall be measured as not less than the width at a lower elevation. The normal depth shall be measured to the underside of that part of the structure for which the excavation is made.

For pavement, normal excavation is the defined width and thickness of the pavement course.

No additional width or depth of trenches excavated in earth or rock shall be allowed at standard circular manholes.

Wherever bell holes are required for jointing pipe, they shall be provided without additional compensation over and above that resulting from measurements as above described.

3. POWDER ACTUATED FASTENERS: Whether or not permitted by local code or ordinance, powder actuated fasteners may not be used except on specific approval of the Owner or the Engineer in writing.

4. PAVEMENT GUARANTEE: The Contractor warrants to the Owner that all materials and workmanship furnished on all pavements and roadways are guaranteed in accordance with the terms of the General Conditions, Section 4, General Guaranty, for a period of one (1) year. The Contractor will remedy any settlements or deficiencies of the pavement surface within this period. All drainage pipe placed by the contractor under pavement carries the same Guarantee.

5. CLEAN-UP FOLLOWING PIPELINE INSTALLATION: Contractor will expedite clean-up and restoration work as required by the Contract Drawings and Specifications. To the maximum extent possible, roadways, drives, drainage ditches, and structures will be restored immediately after the pipeline installation. The restoration or replacement of public or private property should be scheduled as a top priority work item in the execution of this project.

6. PROTECTION OF WORK: The Contractor shall at all times, until final acceptance of the Work, provide protection of the Work, either new or previously existing, from all hazards involved in his operations. All damage suffered by any item of work, including, but not limited to, drains, curbs, doors, equipment, and structures, shall be repaired or the item shall be replaced prior to final acceptance.

7. SPECIAL PRECAUTIONS: At all times during the construction of the project and its component parts, the Contractor shall provide, install, and maintain proper temporary supports, shoring, and bracing to prevent any damage to the work due to all causes. When openings are made in the roof and/or exterior walls, suitable temporary weather tight closures shall be installed and maintained at all times when work is not in progress at that location.

8. FIRE PROTECTION: Welding, flame cutting, or other operations involving the use of flame, arc, or sparking devices will not be allowed without adequate protection.

(End of Section 01232)



THE CITY OF  
**GOOSE CREEK**

BERKELEY CO. EST. 1961 SO. CAROLINA



LOCATION MAP

# PINEVIEW GALVANIZED WATER MAIN REPLACEMENT

ISSUED FOR  
AGENCY APPROVAL



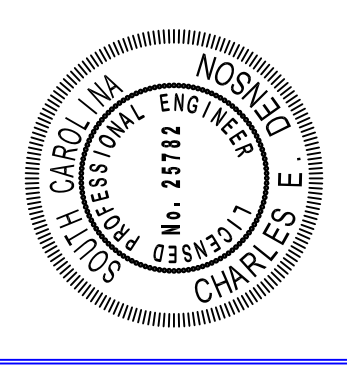
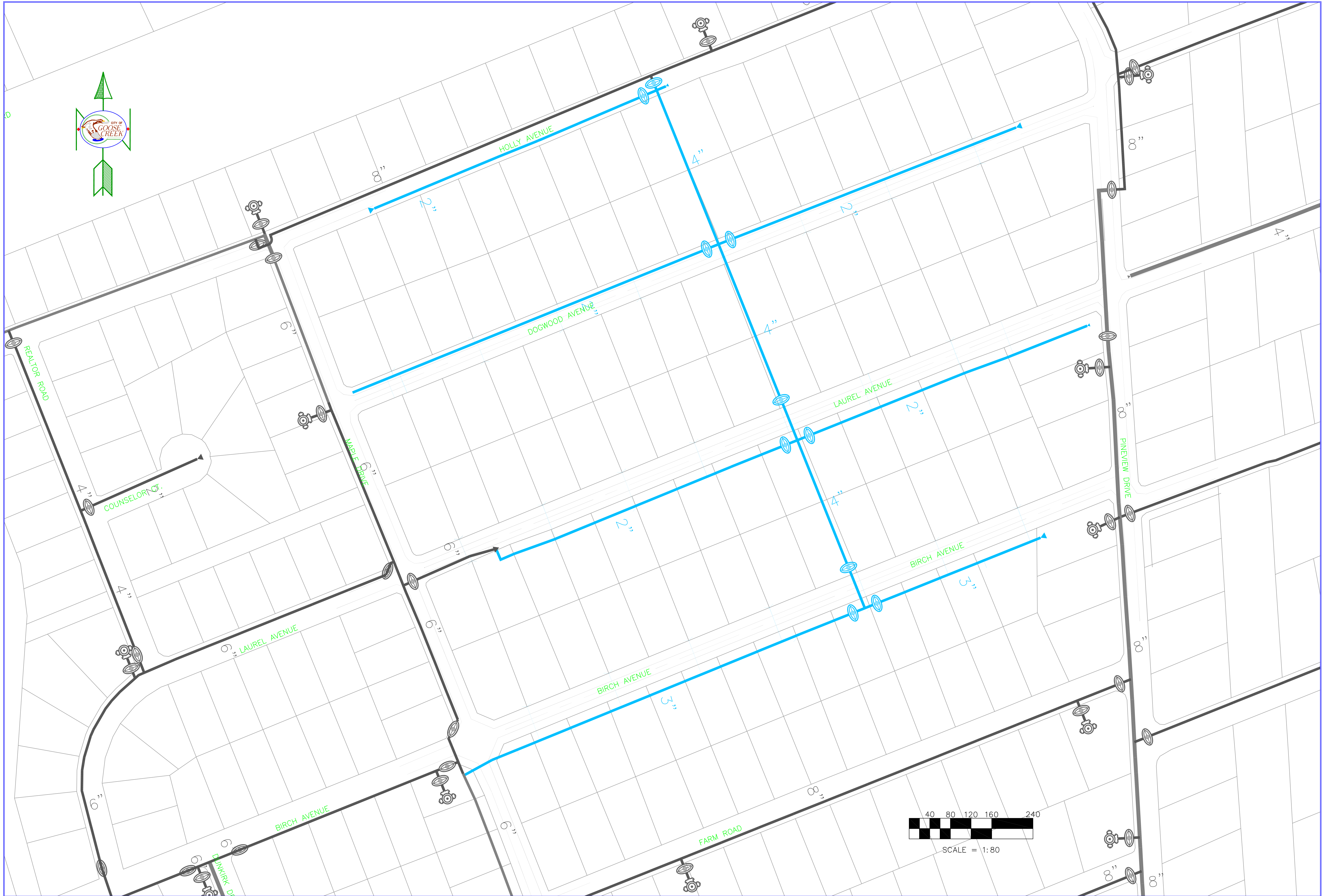

BY	DATE
CED	
REVISIONS	
NO.	1

DEPARTMENT OF PUBLIC WORKS  
 200 BUTTON HALL AVE. PO BOX 1768  
 GOOSE CREEK 29445-1768 (843)824-2200

Pineview 2 Inch  
 Water Main Replacement  
 SOUTH CAROLINA  
 Existing  
 GOOSE CREEK

JOB NO.  
 DATE: 2020-03-1  
 DRAWN: CED  
 CHECKED: CED  
 SCALE: 1" = 40'

SHEET  
 C1  
 5 OF C1



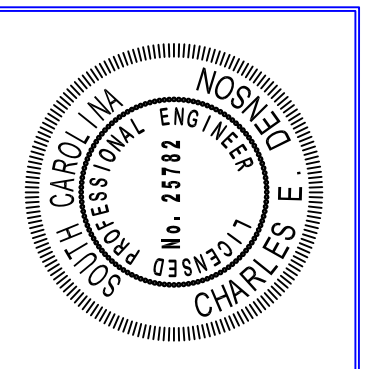
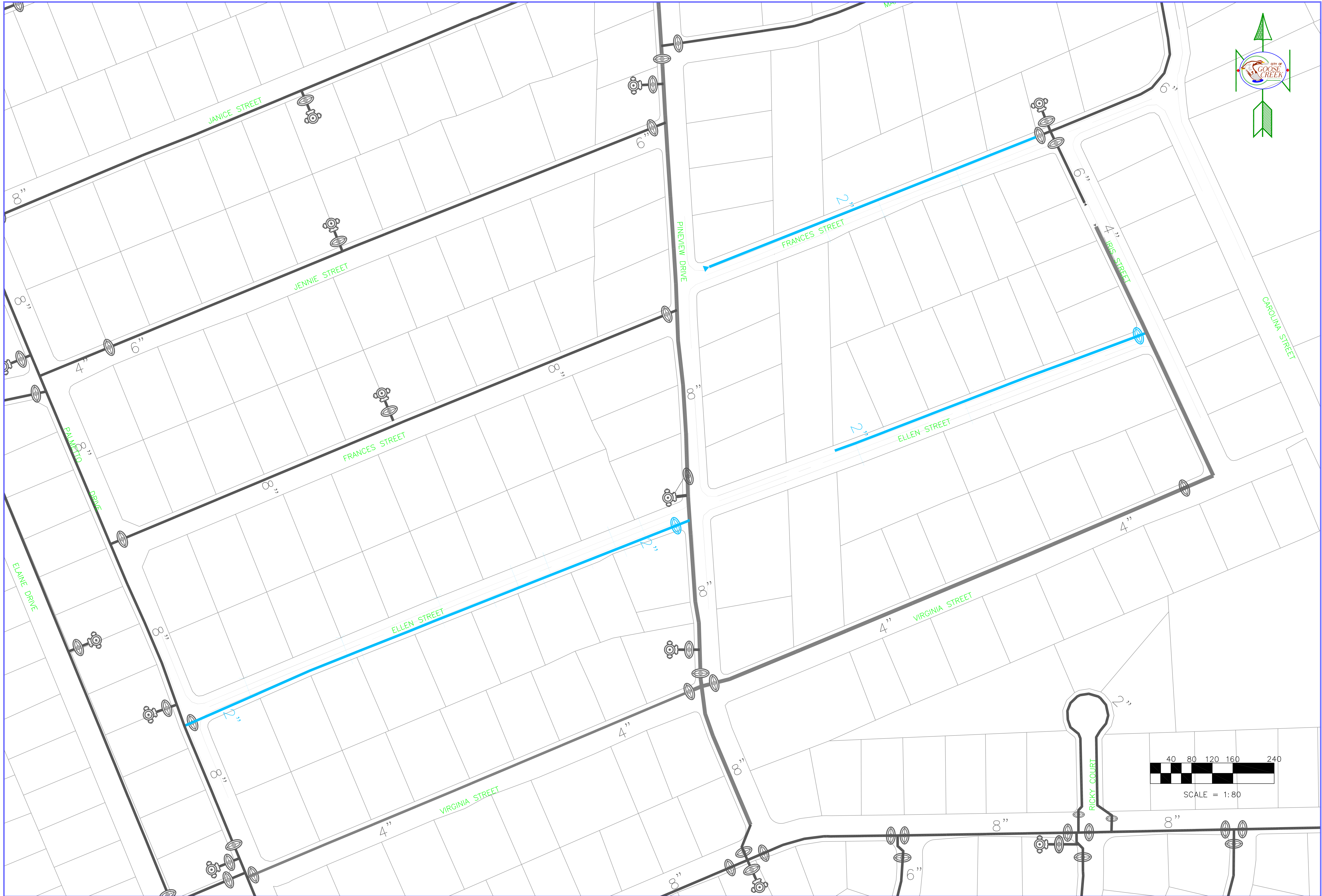

NO.	REVISIONS	DATE
1	SCDOT review comments	CEd/2/23/20

DEPARTMENT OF  
PUBLIC WORKS

200 BUTTON HALL AVE. PO BOX 1768  
GOOSE CREEK 29445-1768 (843)824-2200



Pineview 2"  
Water Main Replacement

GOOSE CREEK SOUTH CAROLINA

Existing

JOB NO.
DATE: 2020-03-1
DRAWN: CED
CHECKED: CED
SCALE: 1" = 40'

SHEET

C1A

5 OF C1



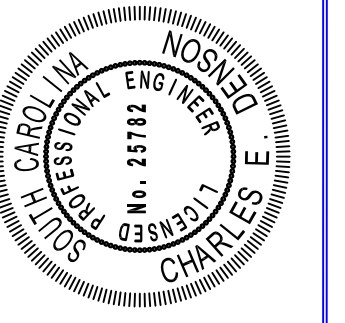
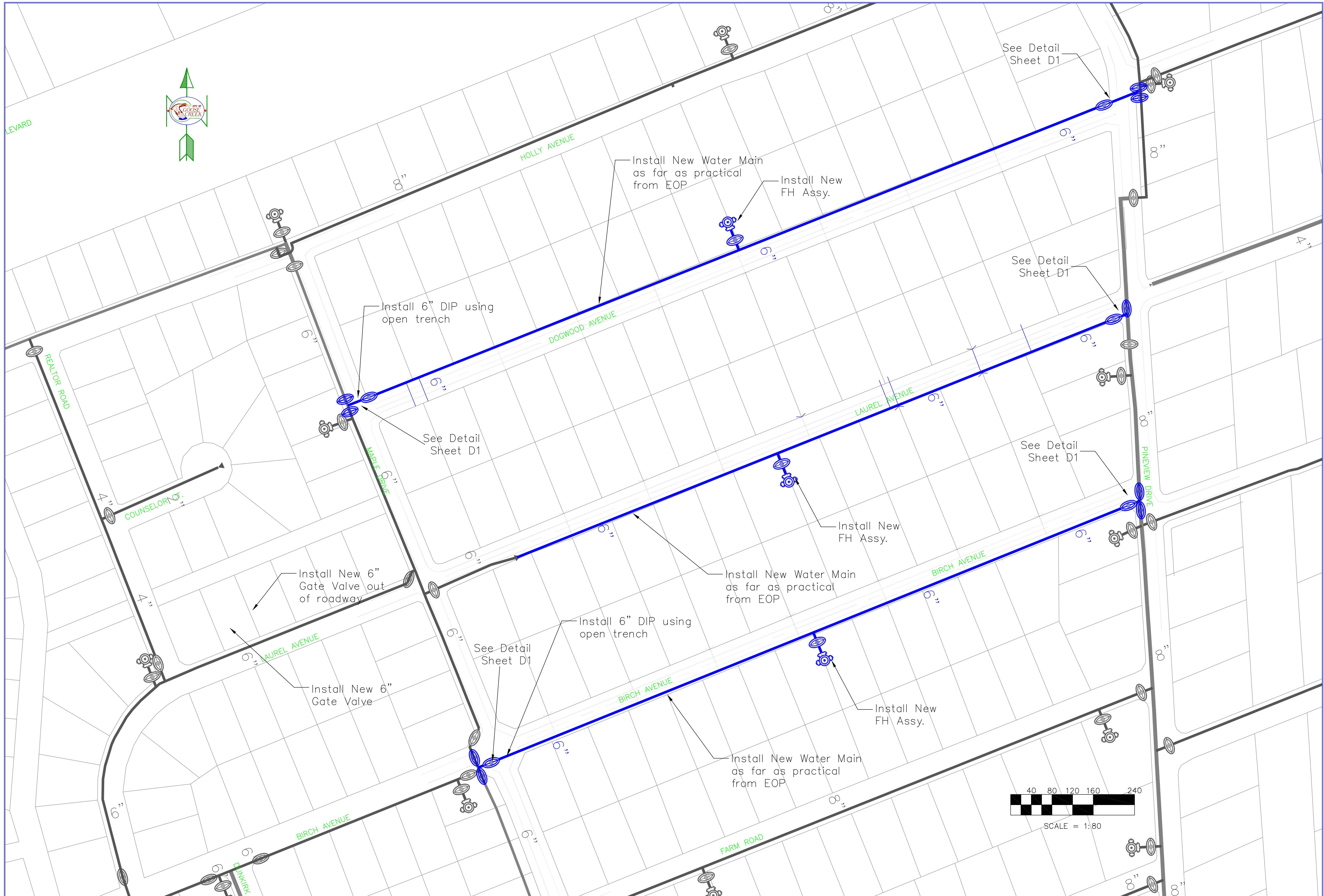

NO.	DATE	BY	REVISIONS
1		CED	

DEPARTMENT OF PUBLIC WORKS  
 200 BUTTON HALL AVE., PO BOX 1768  
 GOOSE CREEK 29445-1768 (843)824-2200



Pineview 2 Inch Water Main Replacement  
 SOUTH CAROLINA  
 GOOSE CREEK Proposed

JOB NO.  
 DATE: 2020-08-14  
 DRAWN: CED  
 CHECKED: CED  
 SCALE: 1" = 40'

SHEET  
**C2**  
 5 OF C1



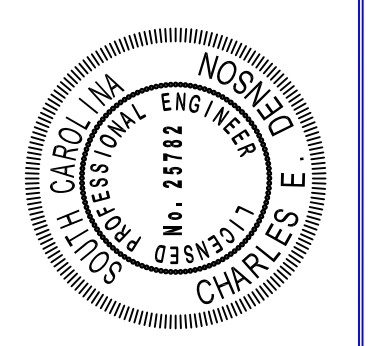
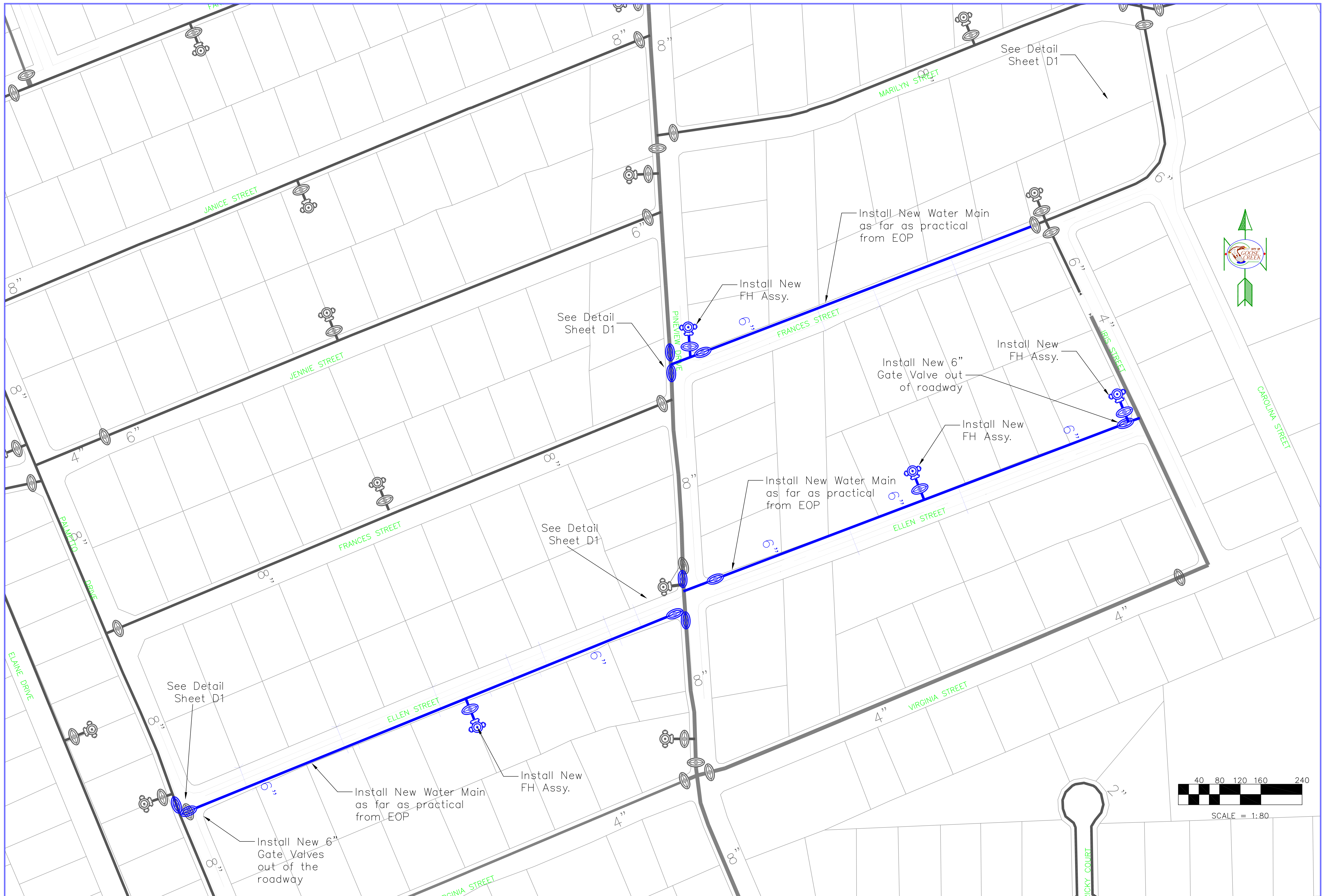

NO.	DATE	BY	REVISIONS
1		CED	

DEPARTMENT OF PUBLIC WORKS  
 200 BUTTON HALL AVE. PO BOX 1768  
 GOOSE CREEK 29445-1768 (843)824-2200



Plineview 2 Inch Water Main Replacement  
 SOUTH CAROLINA  
 GOOSE CREEK  
 Proposed

JOB NO.  
 DATE: 2020-08-14  
 DRAWN: CED  
 CHECKED: CED  
 SCALE: 1" = 40'

SHEET  
**C2A**  
 5 OF C1



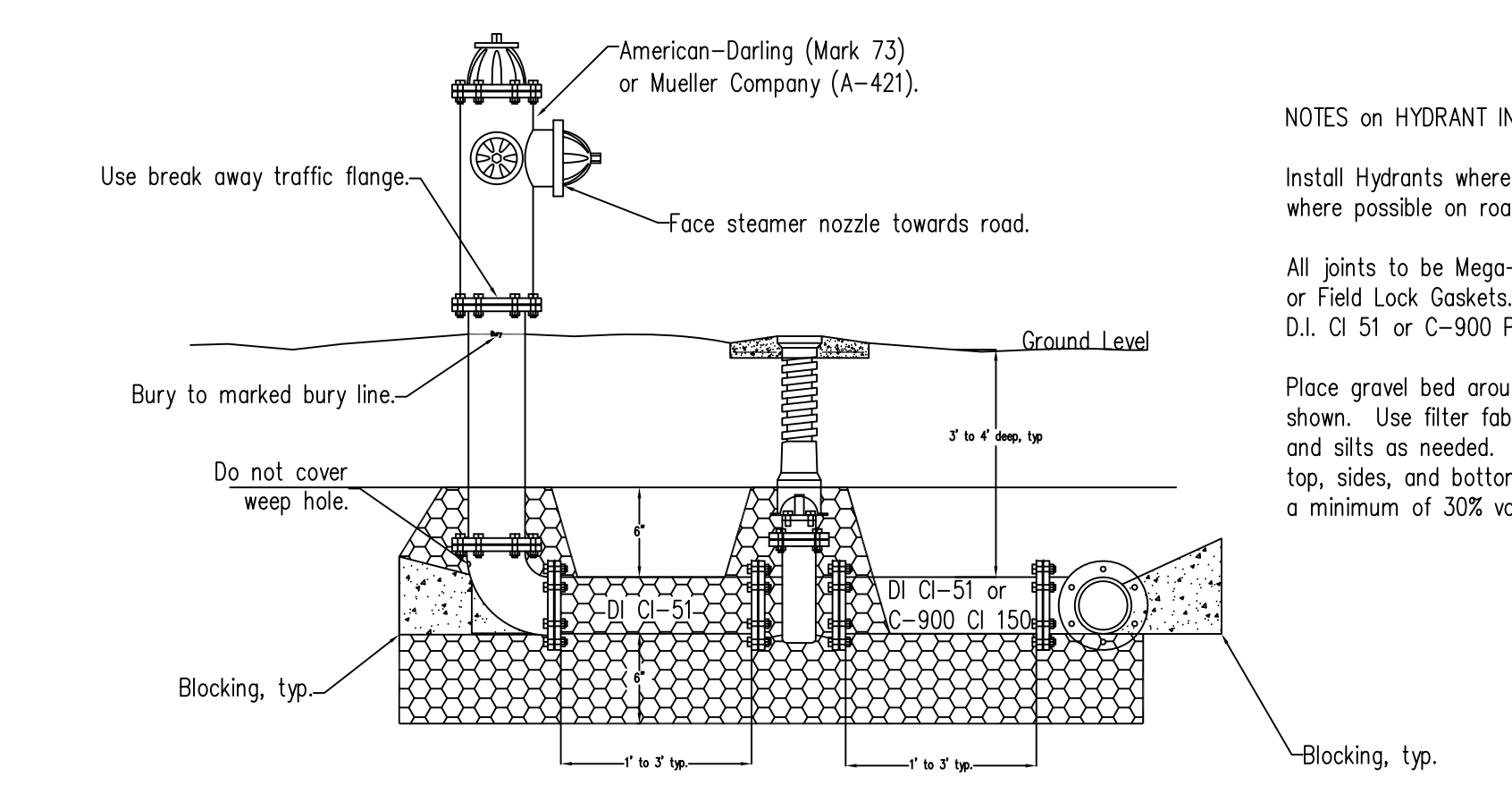
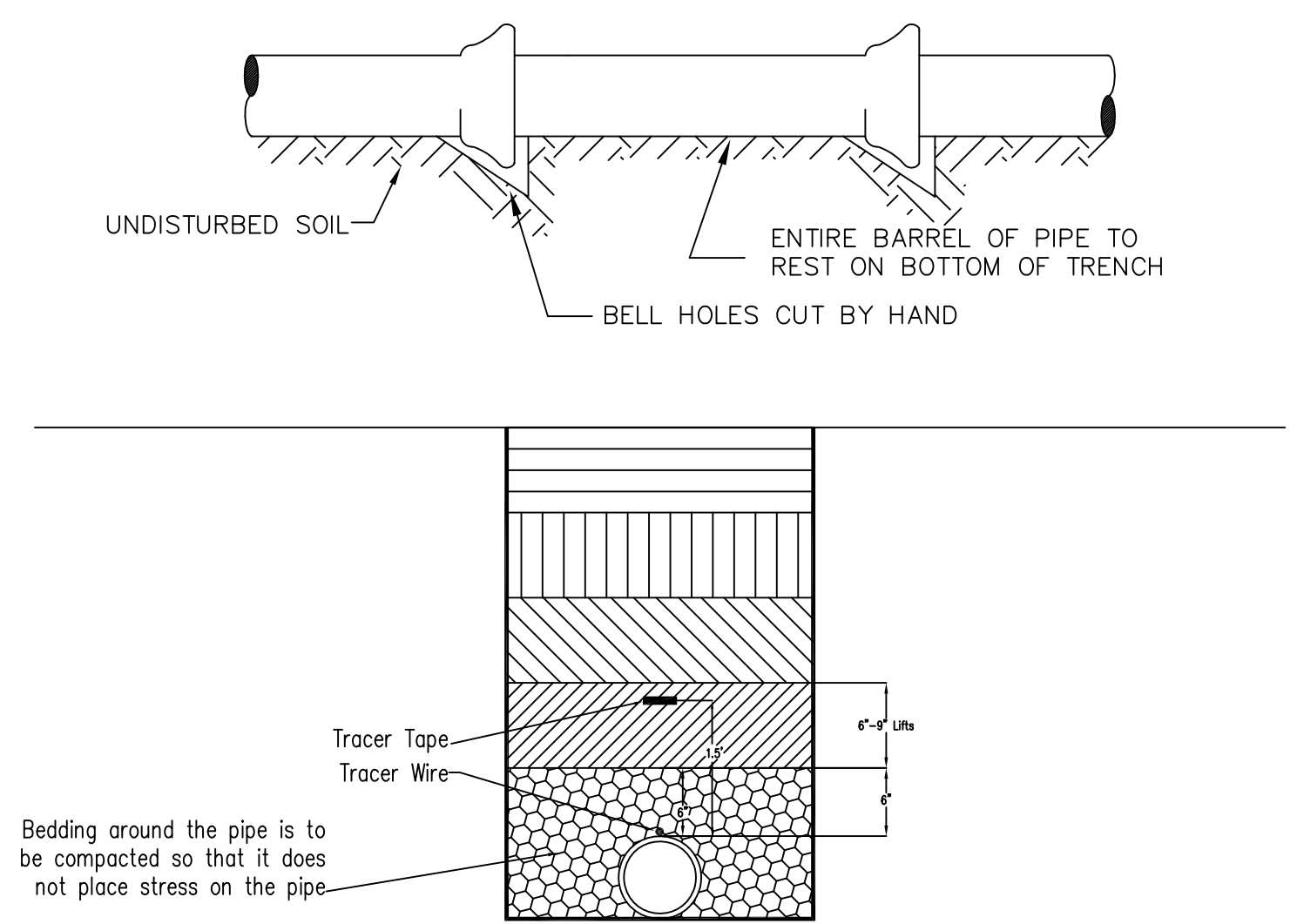
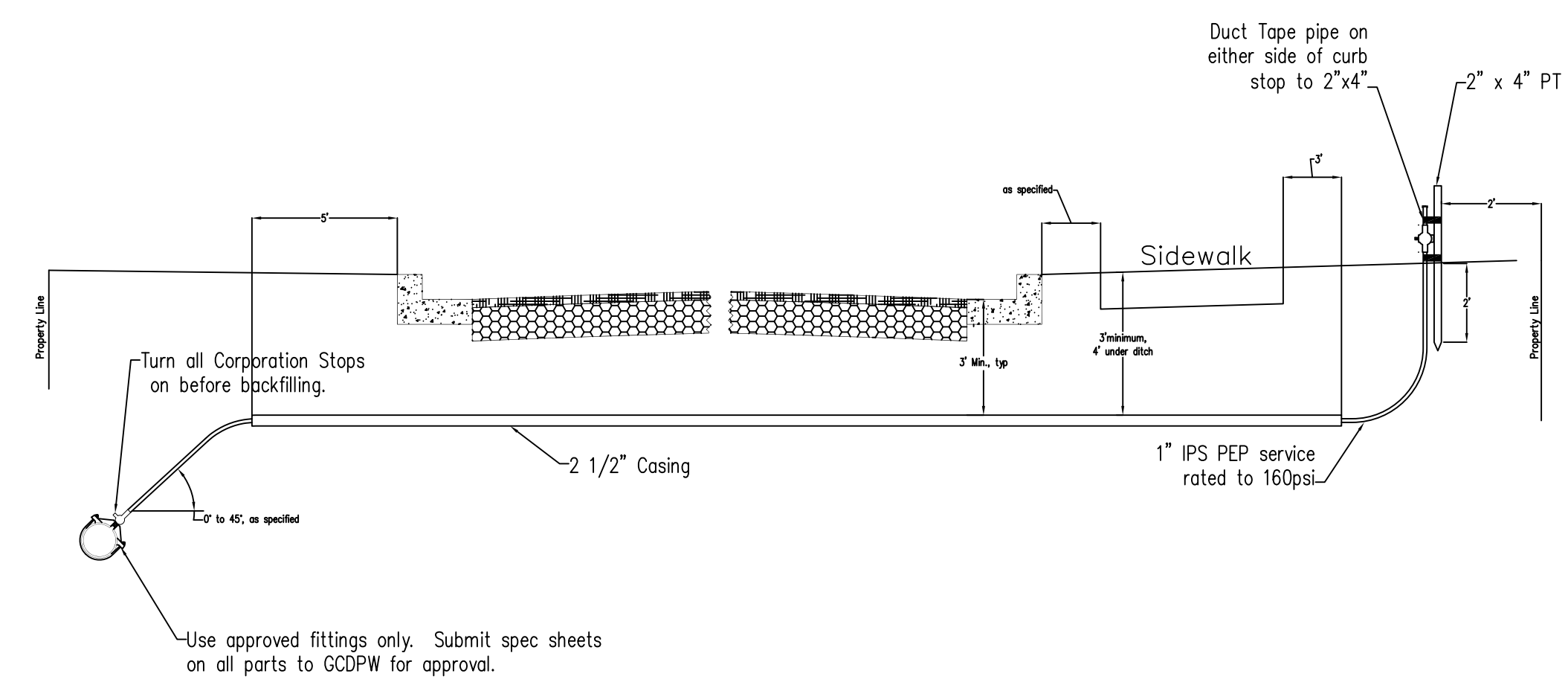
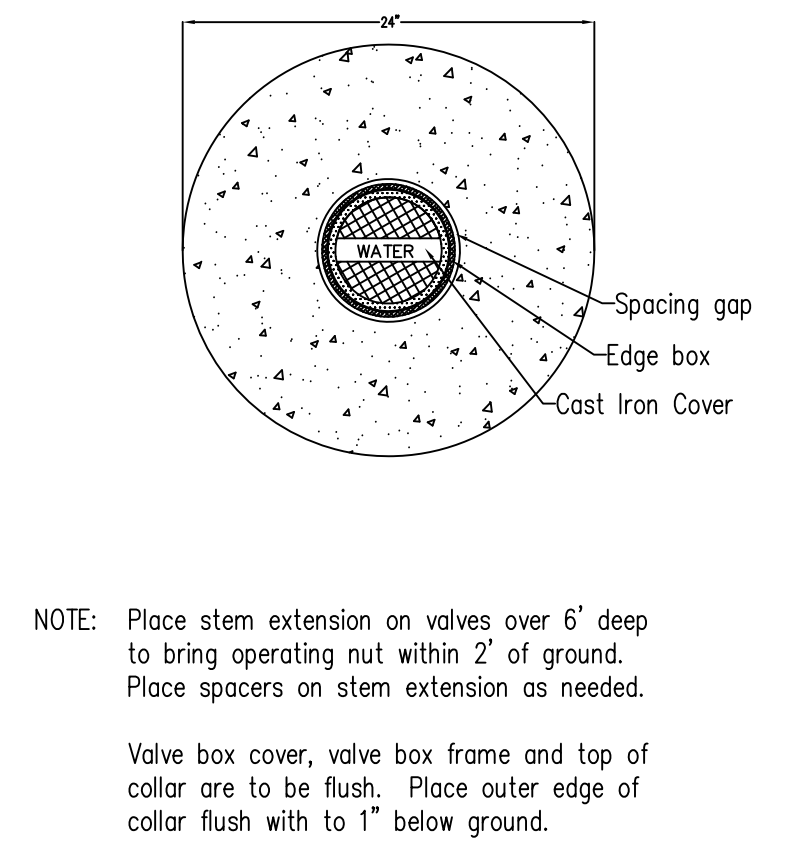
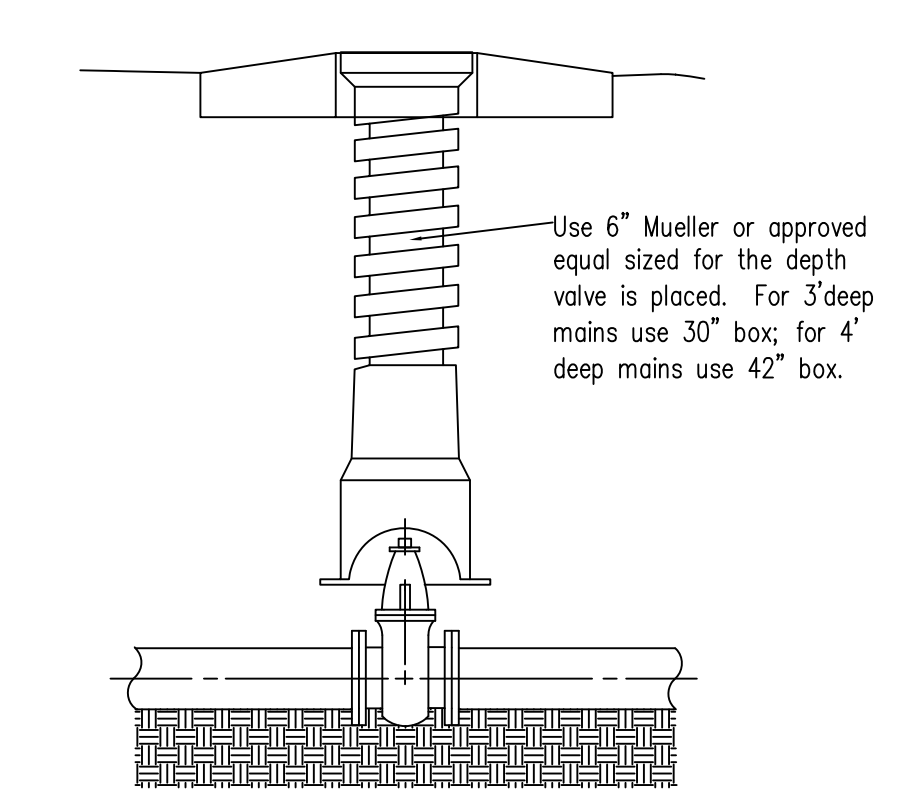
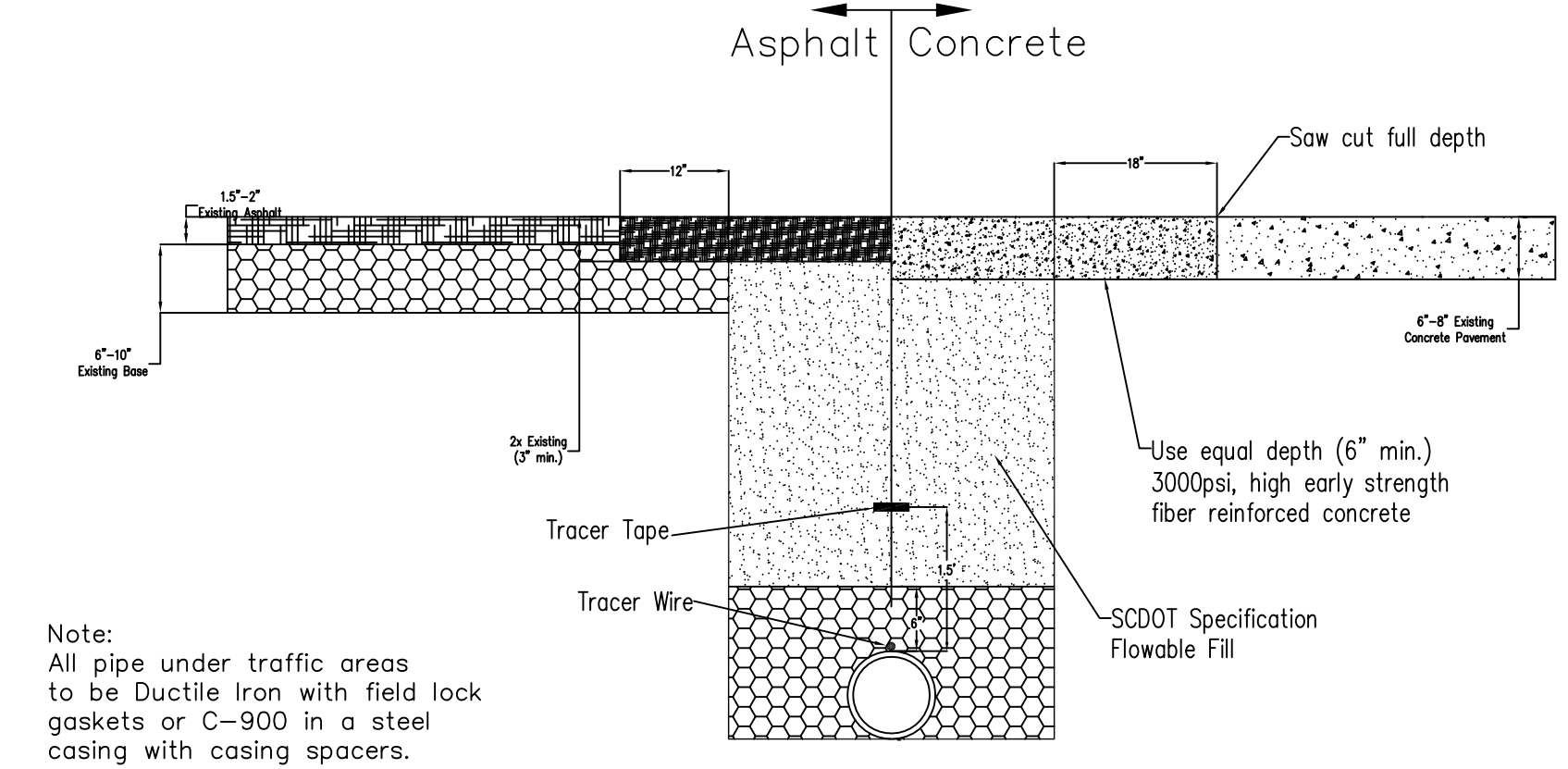
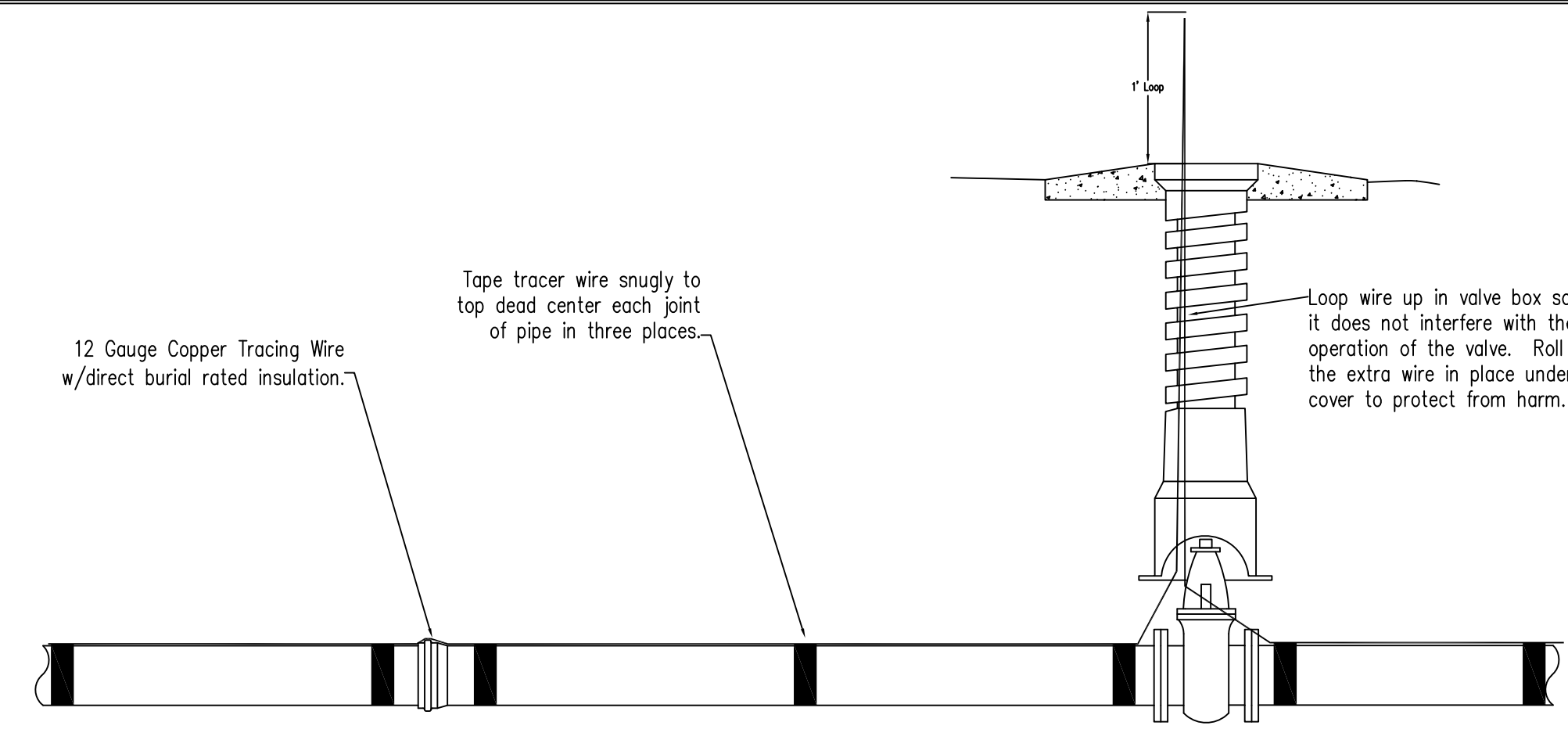
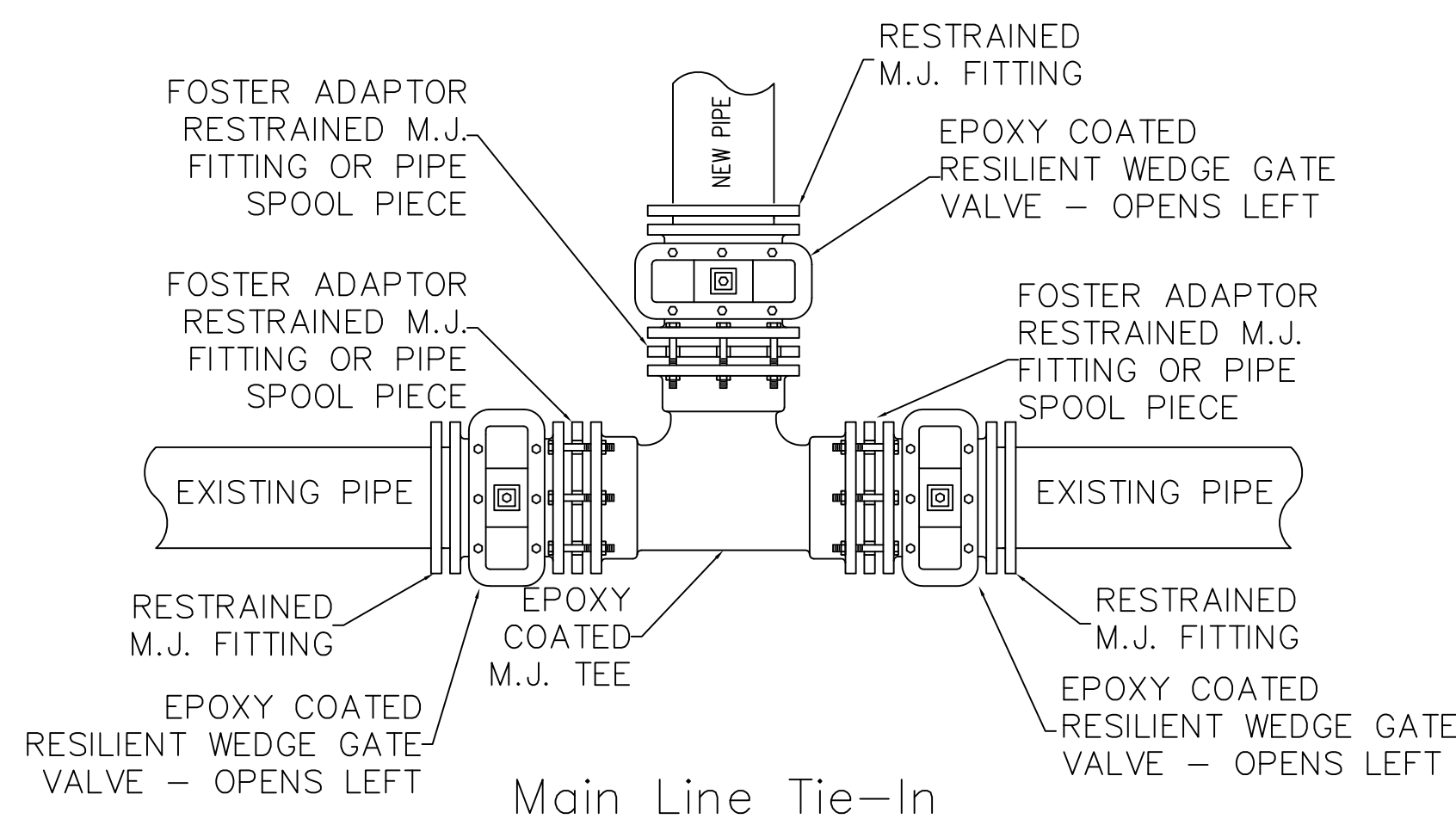

**NOTES ON HYDRANT INSTALLATION:**

Install Hydrants where staked in field, where possible on road side of ditch.

All joints to be Mega-Lugs, Grip Rings, or Field Lock Gaskets. All pipe is to be D.I. Cl 51 or C-900 P.V.C. Class 150.

Place gravel bed around fittings as shown. Use filter fabric in sands and silts as needed. Bed is 6" to top, sides, and bottom as shown and a minimum of 30% void space.

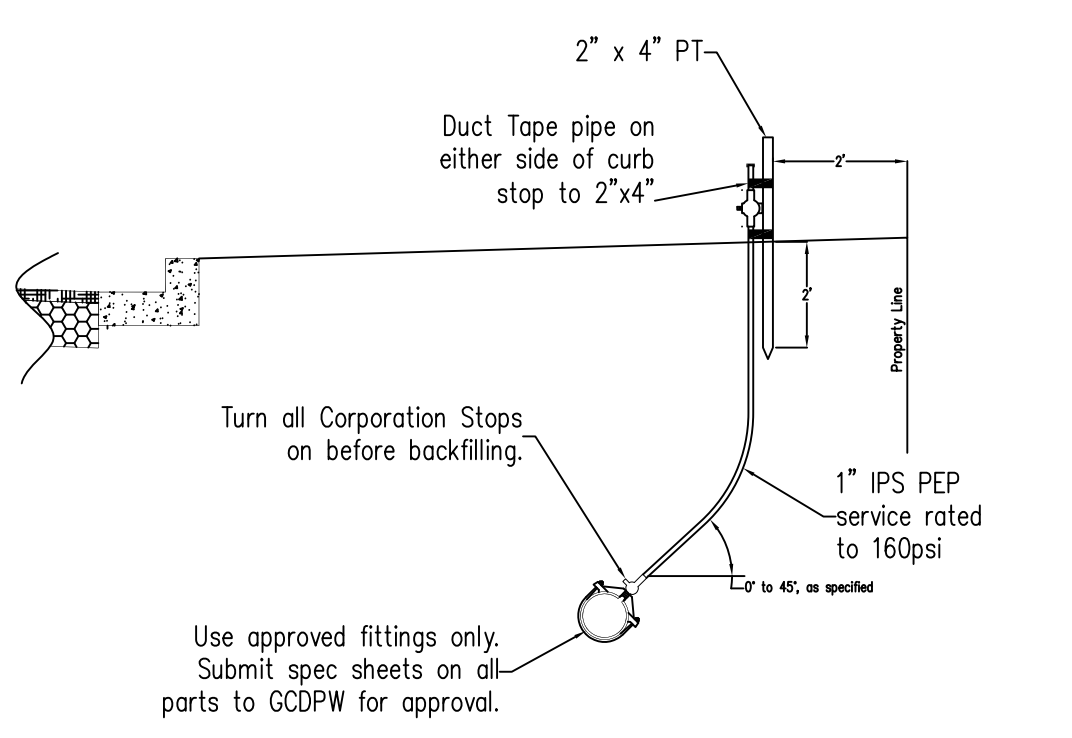
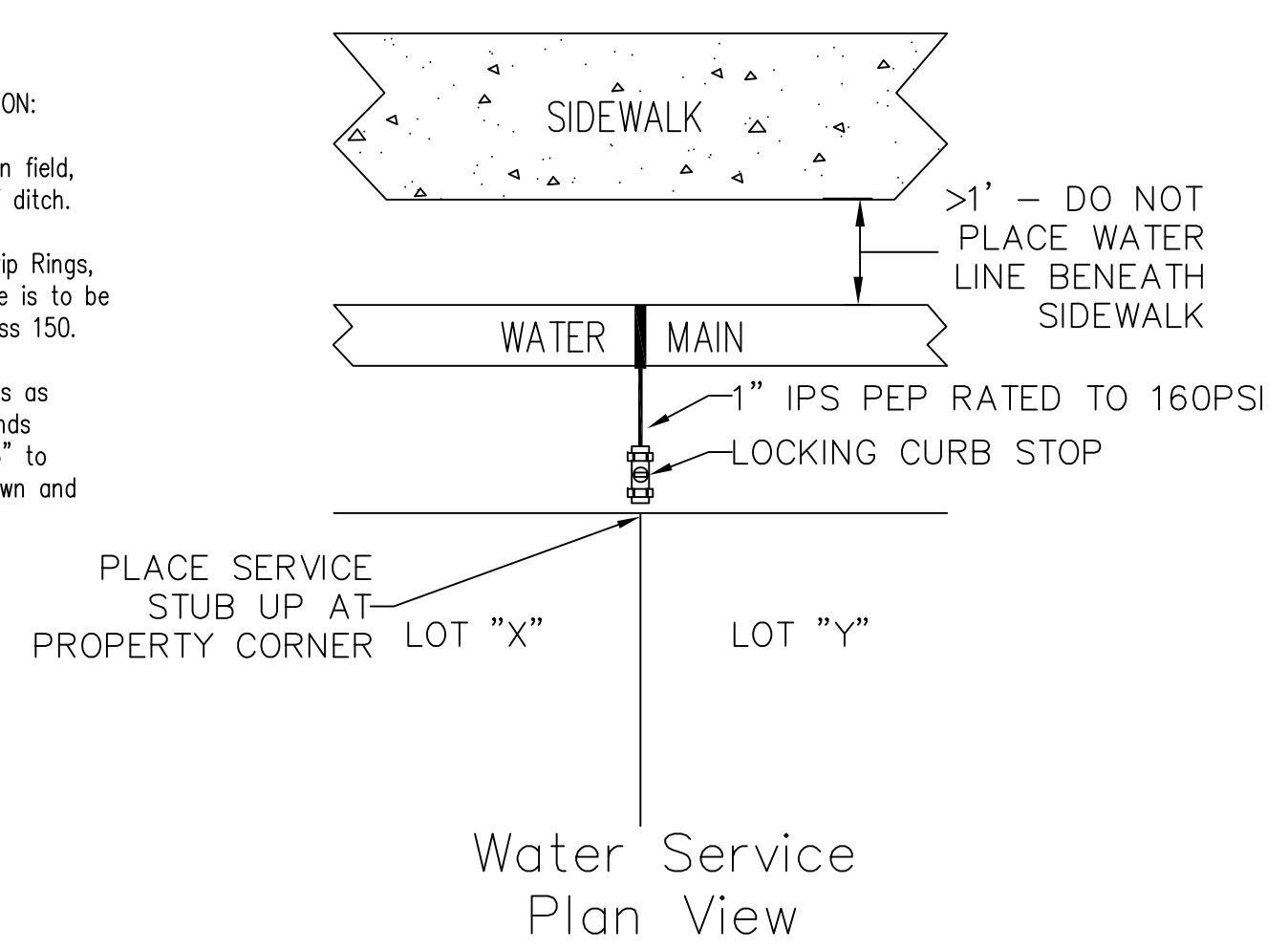

- Main Line and Water Service Parts**
- Water Mains**
1. Pipe: All water mains to be new AWWA C-900 Class 150 PVC or Class 50 Ductile Iron.
  2. Valves: Use Resilient Wedge Gate Valves epoxy coated inside and outside.
  3. Fittings: All fittings are to be Mechanical Joint with Grip Ring or Mega Lug.
  4. Valve Boxes: Use adjustable screw type cast iron boxes set on Valve Box Adapters.
  5. Tracer Wire: Use 12 gauge copper wire with direct burrial U.L. listed insulation. Tape tracer wire to the top of pipe at center and near joints. Loop up 1' in valve boxes.
  6. Underground Splices: Use 3M or equivalent resin filled splice lits to splice tracer wire.
  7. Tie Ins: At the tie in points use a Mechanical Joint Connector on all three legs of the tee.
  8. Valve Box Adapters: Use Adaptor, Inc. Adapter II between all valve boxes and valves.
- Service Connections**
1. Tapping Saddles: Use double U-bolt epoxy coated saddles (Mueller DE2A, Smith Blair 313 or equal).
  2. Corporation Stop: Use Ford F1001-4 or approved equal.
  3. Polyethylene Service: Use 1" IPS rated to 160psi (PE3406) to the curb stop.
  4. Insert Stiffeners: All PEP will use an appropriate size insert stiffener at each pipe end.
  5. Curb Stop: Use Ford B66-444 IPS Curb Stop on each stub-up, and lock out with wire seal.
  6. Meter: Install GCDPW approved Radio Read AMR meter with electronic register. Contractor to provide all materials and labor for commercial installs.
  7. Yoke Assembly: Contact GCDPW Water Department for latest parts list.
  8. Meter Box: Appropriately sized fiber concrete meter box with traffic rated lid with penetration for radio read MXU on standard in ground meter boxes.
  9. Backflow: Use Reduced Pressure, Watts or Equivalent, on commercial domestic taps. Use concrete slab, place RPPA lower port 12" above adjacent ground, with Hot Box or equivalent cover. Irrigation backflow use DCVA if approved, or as specified. DCVA to be placed in below ground box.

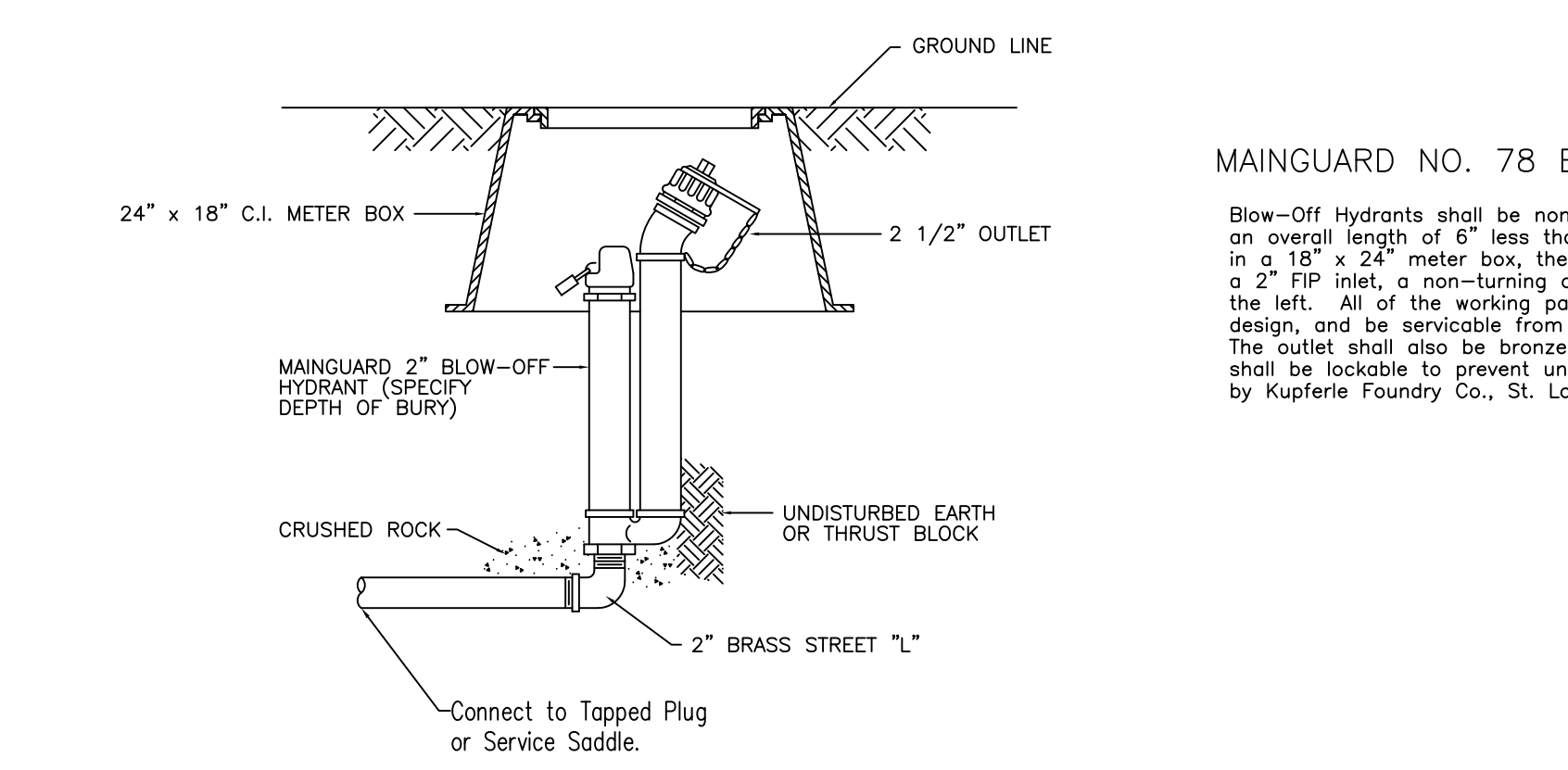

**MAINGUARD NO. 78 BLOW-OFF HYDRANT**

Blow-Off Hydrants shall be non-freezing, self draining type, with an overall length of 6" less than bury depth. Set underground in a 18" x 24" meter box, these hydrants will be furnished with a 2" FIP inlet, a non-turning operating rod, and shall open to the left. All of the working parts shall be of bronze-to-bronze design, and be serviceable from above grade with no digging. The outlet shall also be bronze and be 2-1/2" NST. Hydrants shall be lockable to prevent unauthorized use as manufactured by Kupferle Foundry Co., St. Louis, MO, or approved equal.

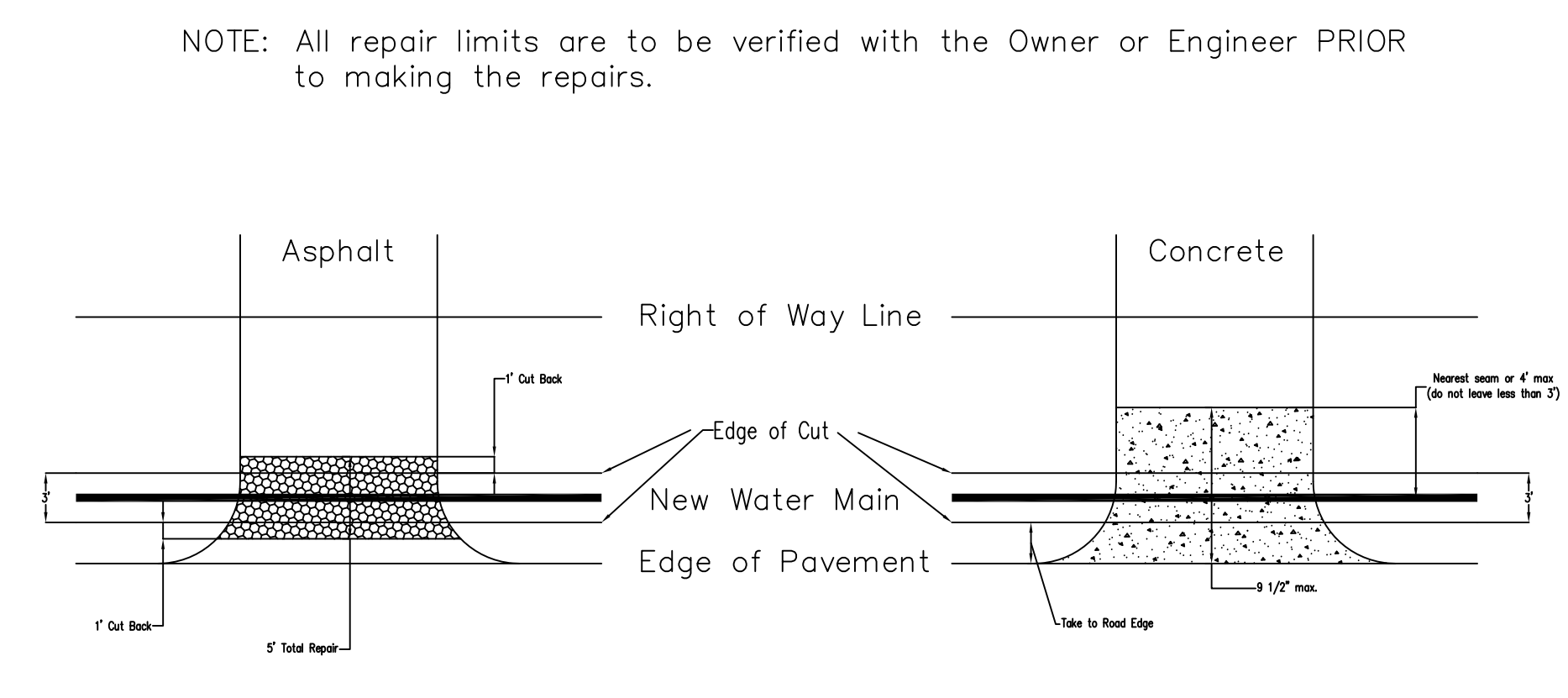

- READ THESE THOROUGHLY**
1. No trees, bushes or landscape plantings are to be removed, without written approval of the Owner.
  2. All pipe fittings are to be inspected prior to backfill. Pipe Tracer Wire to be inspected.
  3. All disturbed areas of ground are to be sodded.
  4. Immediately replace driveways with an approved temporary all weather surface.
  5. The Contractor shall use silt fence between all disturbed areas and undisturbed areas.
  6. Silt fence is to be checked weekly, or more often as needed, and shall be cleaned of any accumulated siltation as needed.
  7. Where silt fence is not used or maintained, the contractor is responsible for cleaning all sediment from ditches at their own expense.

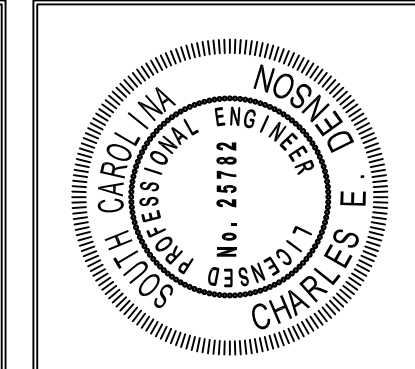
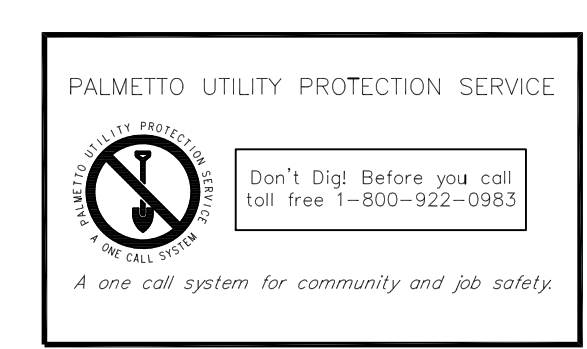

DATE	
BY	
REVISIONS	
NO.	

**DEPARTMENT OF PUBLIC WORKS**

200 BUTTON HALL AVE. PO. BOX 1768  
GOOSE CREEK 29445-1768 (843)382-2200



**WATER DETAILS**

SOUTH CAROLINA

Details

GOOSE CREEK

JOB NO.	
DATE:	02/02/2021
DRAWN:	CED
CHECKED:	CED
SCALE:	1" = N/A

SHEET

**D1**

4 OF 6



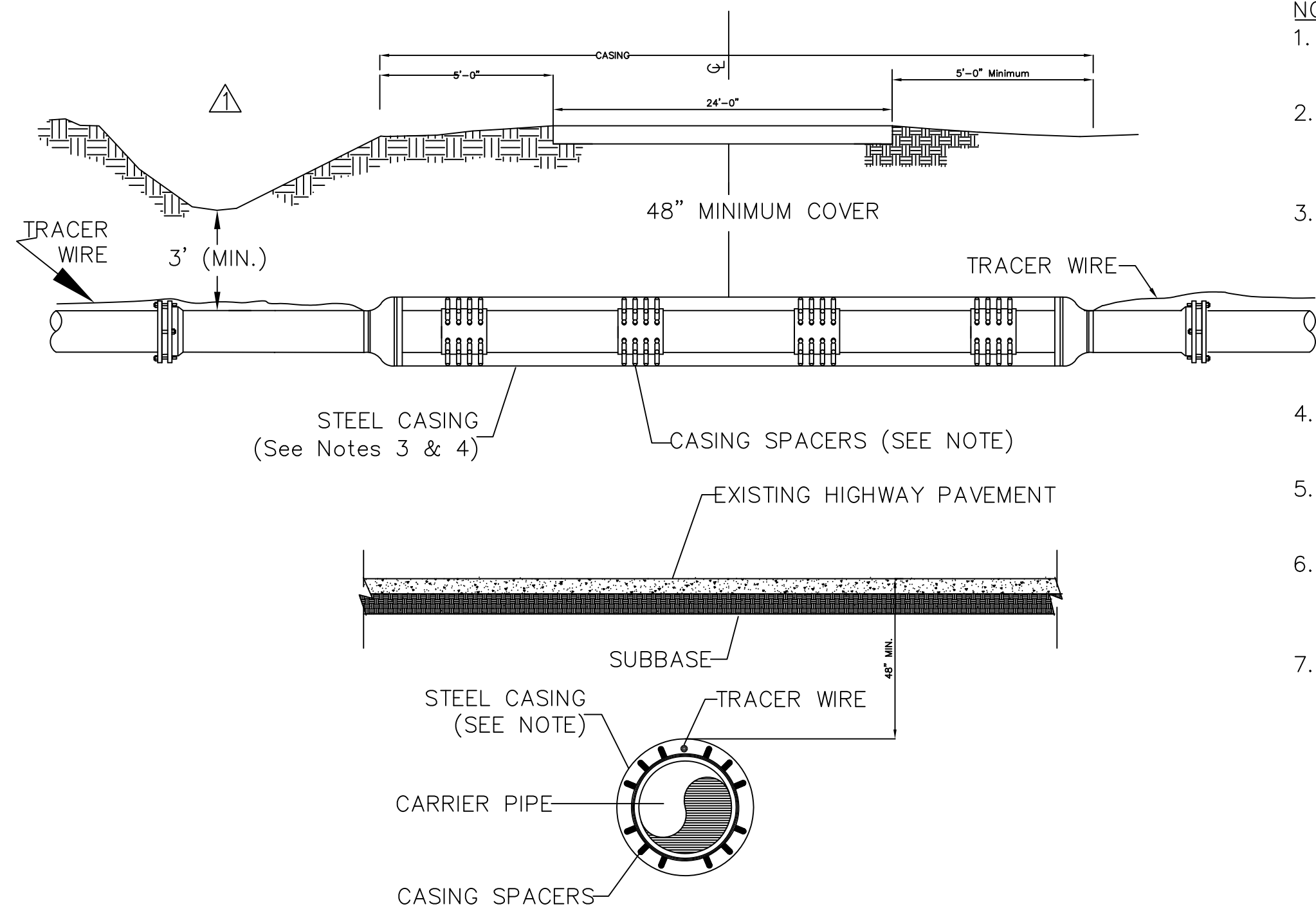

TYPICAL ROADWAY BORE & JACK DETAIL

- NOTES:**
1. STEEL CASING TO EXTEND A MINIMUM OF 5' BEYOND EDGE OF PAVEMENT.
  2. ALL CONSTRUCTION TO BE INSPECTED AND APPROVED BY LOCAL, COUNTY OR STATE ROAD DEPARTMENT.
  3. CONTRACTOR IS RESPONSIBLE FOR COORDINATING WELD INSPECTIONS PRIOR TO PUSHING CASING.
  4. SIZE AND WALL THICKNESS OF CASING TO BE APPROVED BY GCDPW AND SCDOT.
  5. PLUG BOTH ENDS OF CASING WITH CASCADE CASING PLUGS OR GCDPW APPROVED EQUAL.
  6. CASING SPACERS SHALL BE ALL STAINLESS STEEL WITH PLASTIC SLIDES AS MADE BY CASCADE OR GCDPW APPROVED EQUAL.
  7. SPACING OF CASING SPACERS SHALL BE PER MANUFACTURERS SPECIFICATIONS BASED UPON CARRIER PIPE MATERIAL.

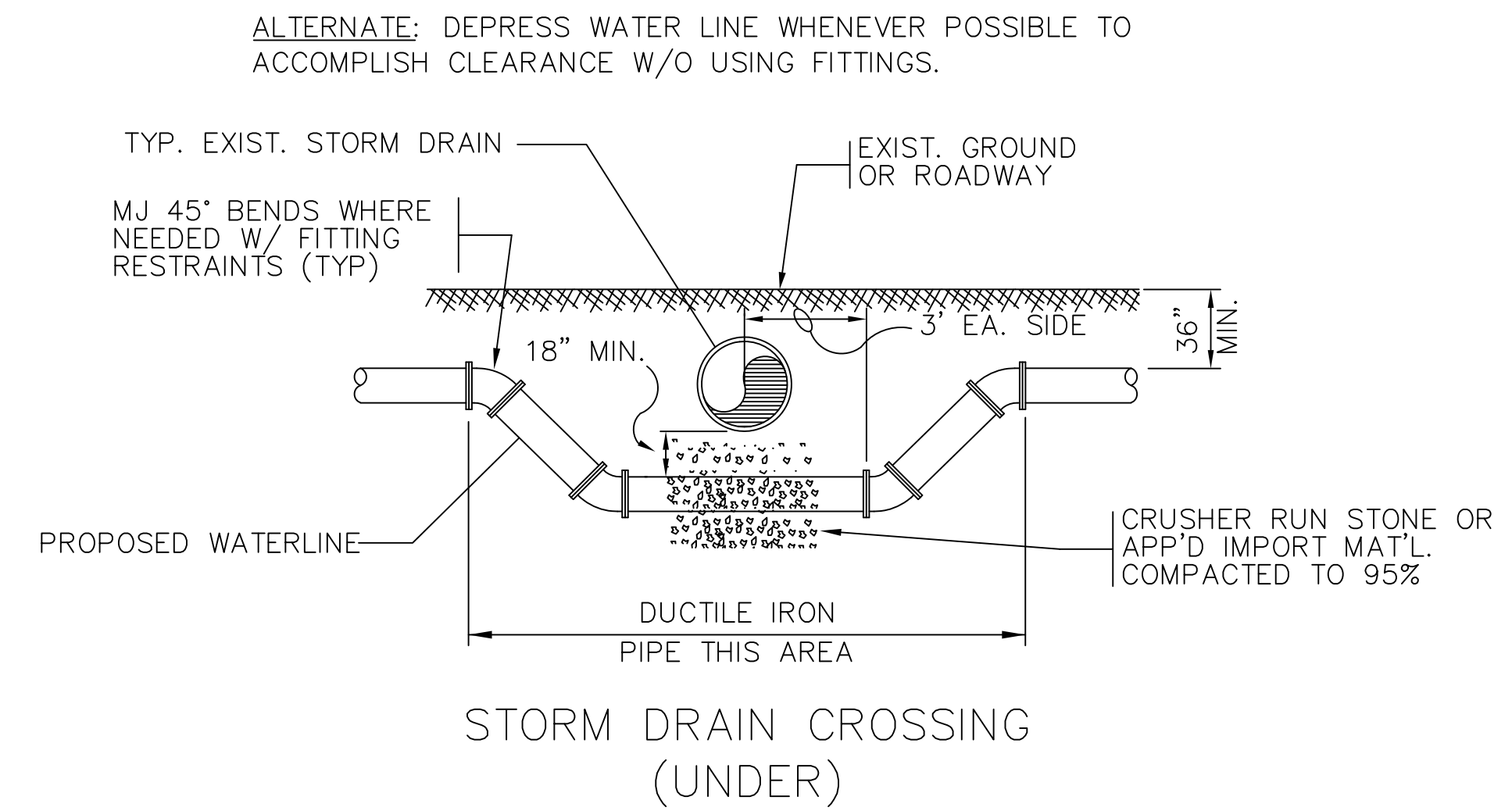

STORM DRAIN CROSSING (UNDER)

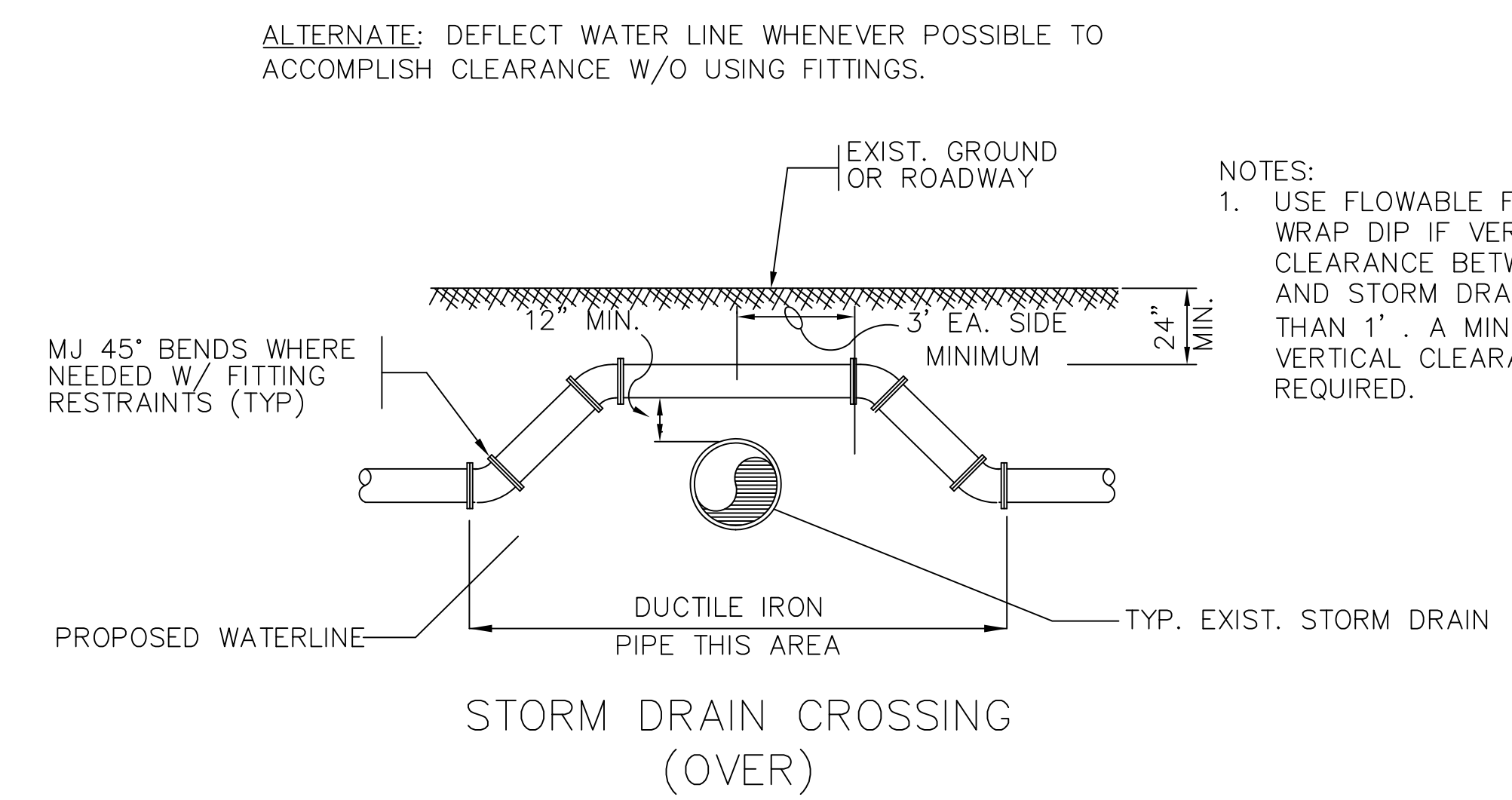

STORM DRAIN CROSSING (OVER)

- NOTES:**
1. USE FLOWABLE FILL AND POLY WRAP DIP IF VERTICAL CLEARANCE BETWEEN WATER AND STORM DRAINAGE IS LESS THAN 1'. A MINIMUM OF 0.5' VERTICAL CLEARANCE IS REQUIRED.

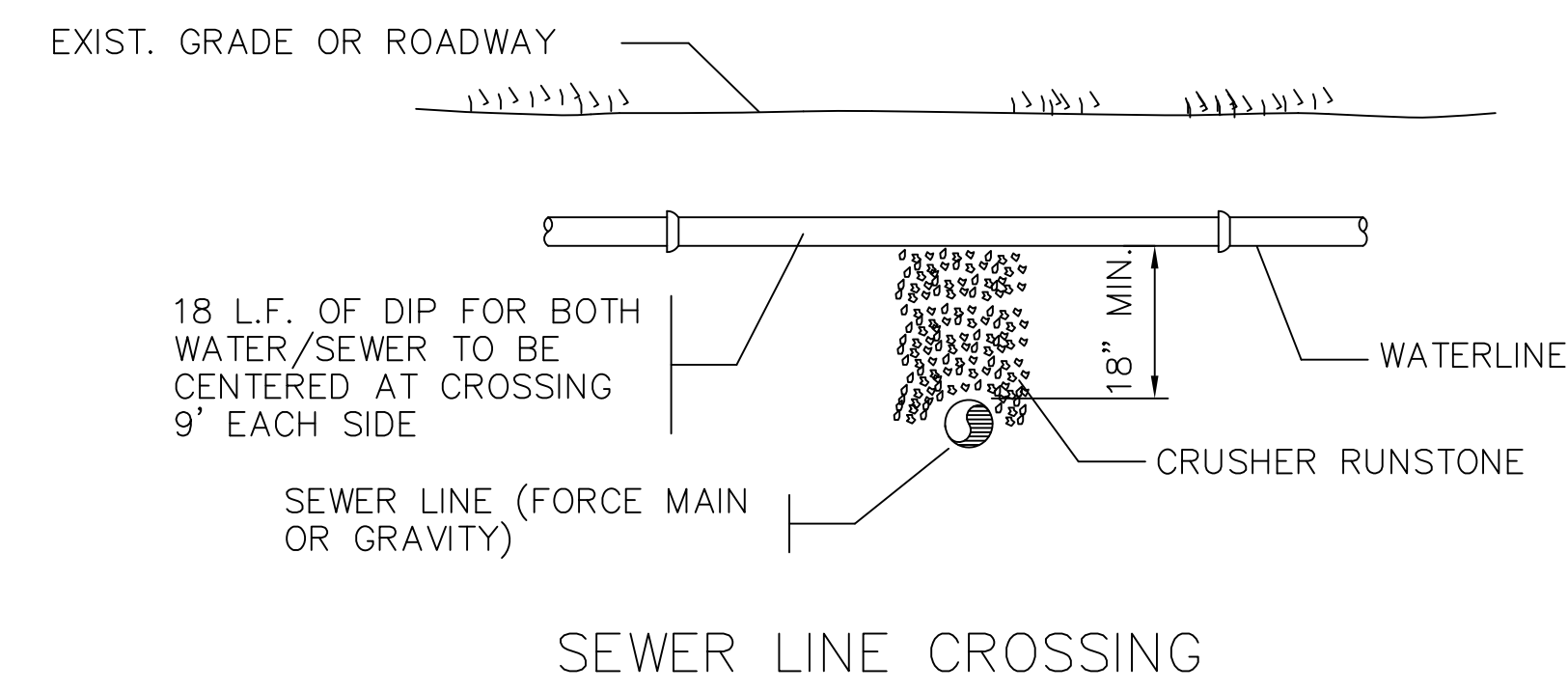
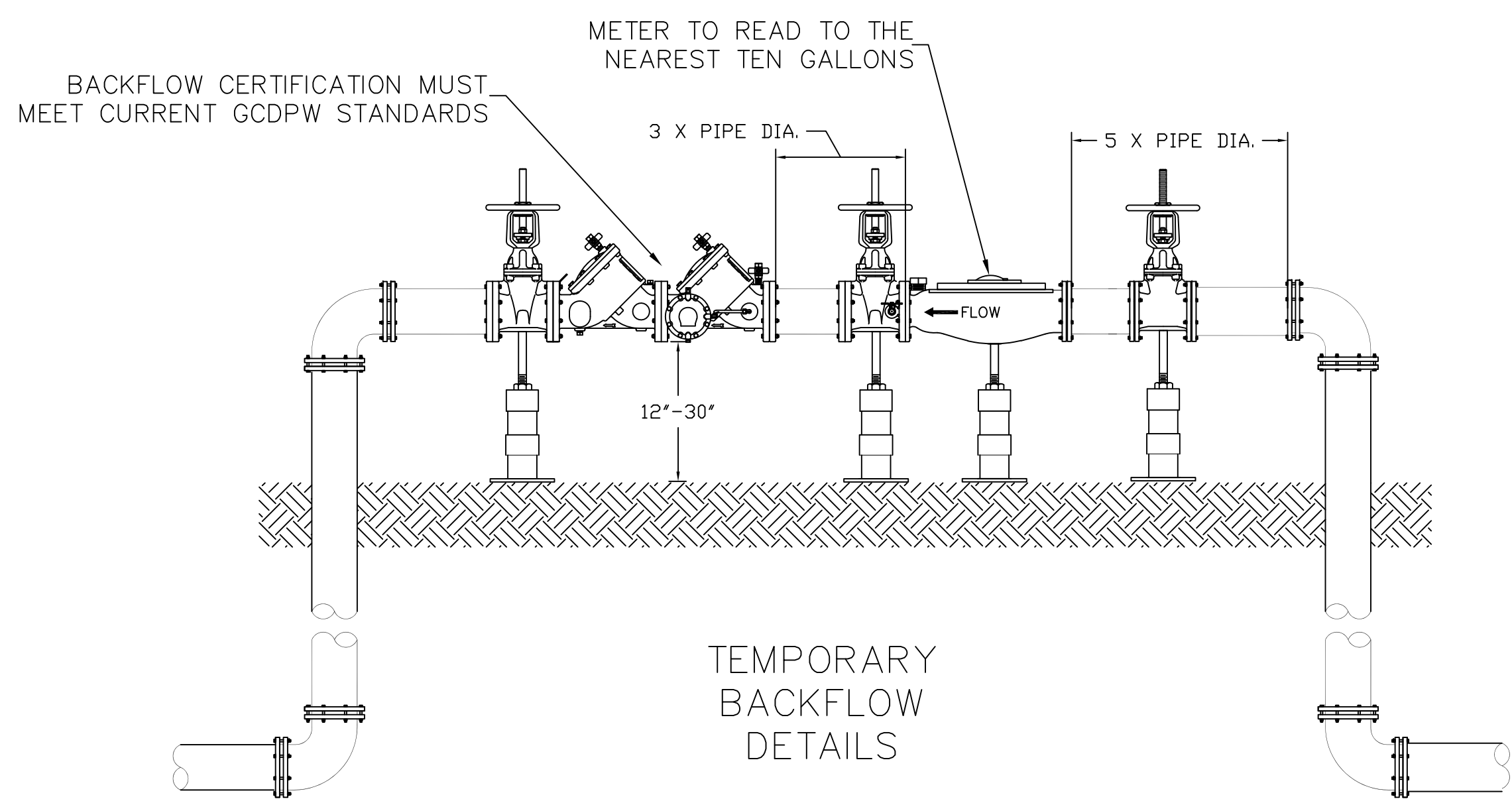

SEWER LINE CROSSING

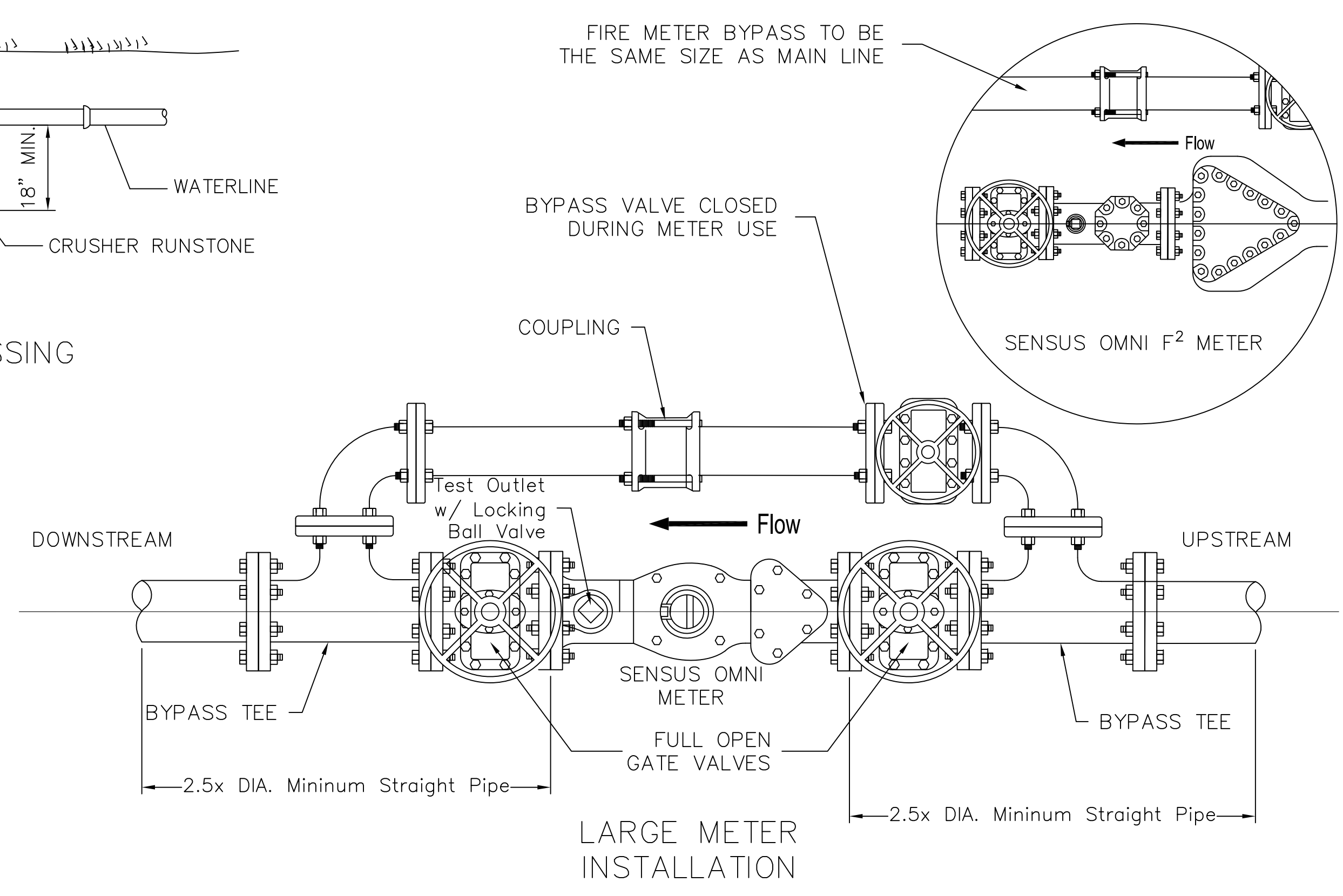

LARGE METER INSTALLATION

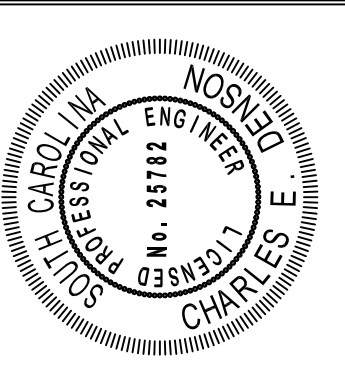

NO.	REVISIONS	BY	DATE

DEPARTMENT OF PUBLIC WORKS  
 200 BUTTON HALL AVE. PO. BOX 1768  
 GOOSE CREEK 29445-1768 (843)3824-2200



WATER DETAILS  
 SOUTH CAROLINA  
 Details  
 GOOSE CREEK

JOB NO.  
 DATE: 02/02/2021  
 DRAWN: CED  
 CHECKED: CED  
 SCALE: 1" = N/A

SHEET  
 D2  
 5 OF 6



**WATER NOTES:**

1. WATER INSTALLATION SHALL BE IN ACCORDANCE WITH "TEN STATE STANDARDS," S.C.D.H.E.C., AND GOOSE CREEK DEPARTMENT OF PUBLIC WORKS (GCDPW) REQUIREMENTS.
2. CONTRACTOR SHALL BE FAMILIAR WITH ALL REQUIREMENTS OF THE GCDPW AND SHALL NOTIFY GCDPW PRIOR TO BEGINNING CONSTRUCTION AND SCHEDULE ALL INSPECTIONS 72 HOURS IN ADVANCE.
3. RADIUS (DEFLECT) WATER LINES IN LIEU OF FITTINGS IN ACCORDANCE WITH THE MANUFACTURER'S SPECIFICATIONS. DEFLECTION NOT TO EXCEED 75% OF MANUFACTURER'S RECOMMENDATION.
4. ALL WATER LINES SHALL HAVE A MINIMUM DIAMETER OF 4", A MINIMUM COVER OF 36" AND A MAXIMUM COVER OF 48". ALL UTILITY CROSSINGS, I.E. STORM DRAINAGE & SANITARY SEWER, SHALL HAVE A FULL SECTION OF D.I.P. CENTERED AT THE CROSSING IN ACCORDANCE WITH S.C.D.H.E.C. AND GCDPW REQUIREMENTS.
5. ALL TEES, BENDS, PLUGS AND HYDRANTS ON LINES 3 INCHES INSIDE DIAMETER OR LARGER SHALL BE PROVIDED WITH THRUST BLOCKING, TIE RODS, OR OTHER APPROVED METHOD OF RESTRAINT PER GCDPW.
6. THE CONTRACTOR SHALL VERIFY THE LOCATION AND ELEVATION OF ALL EXISTING UTILITIES PRIOR TO BEGINNING WORK.
7. ALL WATER LINES UNDER TRAFFIC AREAS SHALL BE:
  - A. DUCTILE IRON WITH FIELD LOCK GASKETS POLYWRAPPED TO GCDPW SPECIFICATIONS OR
  - B. DUCTILE IRON IN A STEEL CASING WITH CASING SPACERS.

THE STEEL CASING OR D.I.P. SHALL EXTEND A MINIMUM OF 3 LF BEYOND THE BACK OF CURB.
8. UPON COMPLETION OF CONSTRUCTION OF THE WATER SYSTEM, THE APPROVAL PROCEDURE SHALL BE AS FOLLOWS:
  - A. A PRESSURE TEST IN ACCORDANCE WITH GCDPW REQUIREMENTS WILL BE SCHEDULED BY THE ENGINEER AND WITNESSED BY GCDPW AND THE ENGINEER.
  - B. AFTER A PASSING PRESSURE TEST, THE CONTRACTOR SHALL TAKE REQUIRED SAMPLES FOR BACTERIAL TESTING.
  - C. A COMPLETE WATER SYSTEM AS-BUILT DRAWING IN A FORMAT ACCEPTABLE TO GCDPW SHALL BE PROVIDED FOR FINAL INSPECTION.
  - D. ANY DEFICIENCIES WILL BE CORRECTED BY THE CONTRACTOR AND FINAL INSPECTION RESCHEDULED.
9. ALL VALVES AND FIRE HYDRANTS SHALL OPEN COUNTER-CLOCKWISE AS PER GCDPW REQUIREMENTS.
10. UNDER NO CIRCUMSTANCES SHALL VALVES OR FIRE HYDRANTS BE PLACED IN SIDEWALKS, CURB AND GUTTER OR ROADWAYS WITHOUT SPECIFIC WRITTEN APPROVAL FROM GCDPW.
11. FIRE HYDRANTS SHALL BE PLACED AS FAR AS PRACTICAL FROM THE ROADWAY (SEE DETAIL).

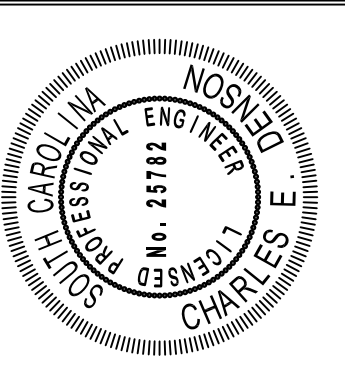

NO.	REVISIONS	BY	DATE

DEPARTMENT OF PUBLIC WORKS  
 200 BUTTON HALL AVE. PO. BOX 1768  
 GOOSE CREEK 29445-1768 (843)824-2200

SOUTH CAROLINA  
 WATER DETAILS  
 Details  
 GOOSE CREEK

JOB NO.
DATE: 02/02/2021
DRAWN: CED
CHECKED: CED
SCALE: 1" = N/A

SHEET  
D3  
 6 OF 6